



~est. 1990
CANAM
pipe & supply



HUH2 - *Hydronic Unit Heater*

SRH2 - *Steam Rig Heater*

This manual covers installation, maintenance,
repair, and replacement parts.



Industrial Grade Heat-Exchanger Unit Heaters

1 Ex d e IIB (T4-T2) Gb X, IP55



WARNING!

Please adhere to all instructions published in this manual.
Failure to do so may be dangerous and may void your warranty.

*The heat-exchanger core is not field repairable.
Contact factory for a replacement core if fluid leakage occurs.*

Model Coding

Heater Model Code & Option Codes

Model Code		Option Codes																																				
HUH	2 - 12 - 1 - E - 230 3 50 - E - T4	H1, C3, etc.																																				
Model Series		Options																																				
SRH HUH		H1 Heresite Coated Core H2 Heresite Coated Cabinet H3 Heresite Coated Core & Cabinet D2 Disconnect Switch (20 Amp) C2 [†] Connection, 2" MNPT Sch 80 Fitting C3 [†] Connection, 2" FNPT 300lb Raised Face Flange S Stainless Steel Cabinet ZZ Special Build (Factory Assigned)																																				
Generation		T- Code*																																				
For major revisions		T4 135°C (max) T3 200°C (max) T2 300°C (max)																																				
Fan Size		Motor Type																																				
12 Inches 12 16 Inches 16 20 Inches 20 24 Inches 24 30 Inches 30		E Hazardous Location																																				
Tube Passes		Motor[^]																																				
1 Pass 1 3 Pass 3 5 Pass 5 7 Pass 7	SRH & HUH steam units are 1 _{pass} only Not available on 12" fan size Not available on 12", 16", & 20" fan sizes	<table border="1" style="width: 100%; border-collapse: collapse;"> <thead> <tr> <th>Voltage</th> <th>Phase</th> <th>Frequency</th> </tr> </thead> <tbody> <tr><td>115</td><td>1</td><td>60</td></tr> <tr><td>230</td><td>1</td><td>60</td></tr> <tr><td>460</td><td>3</td><td>60</td></tr> <tr><td>220</td><td>1</td><td>50</td></tr> <tr><td>230</td><td>1</td><td>50</td></tr> <tr><td>220</td><td>3</td><td>50</td></tr> <tr><td>230</td><td>3</td><td>50</td></tr> <tr><td>240</td><td>3</td><td>50</td></tr> <tr><td>380</td><td>3</td><td>50</td></tr> <tr><td>400</td><td>3</td><td>50</td></tr> <tr><td>415</td><td>3</td><td>50</td></tr> </tbody> </table>	Voltage	Phase	Frequency	115	1	60	230	1	60	460	3	60	220	1	50	230	1	50	220	3	50	230	3	50	240	3	50	380	3	50	400	3	50	415	3	50
Voltage	Phase	Frequency																																				
115	1	60																																				
230	1	60																																				
460	3	60																																				
220	1	50																																				
230	1	50																																				
220	3	50																																				
230	3	50																																				
240	3	50																																				
380	3	50																																				
400	3	50																																				
415	3	50																																				
Approval Type																																						
Customs Union (EAC) E																																						

- [^] IEC motors are to be operated at ±5% of the nameplate voltage.
- [†] Thread-on fittings are shipped loose.
- * The hazardous location T-code = max fluid inlet temp + 10°C safety factor.
 - T4 = 125°C max fluid inlet temperature + 10°C = 135°C.
 - T3 = 190°C max fluid inlet temperature + 10°C = 200°C.
 - T2 = 290°C max fluid inlet temperature + 10°C = 300°C.
- (Eg) Steam Heater @ 30 psi has an inlet temp. of 134°C + 10°C = 144°C. Therefore the T-code is T3.

Physical Dimensions (12 inch to 30 inch models)

Note: Inlet and Outlet coupling connection locations can be reversed in the field by rotating the core.

Mounting Holes, 5/8" 11 UNC

L max.

I

E

B

K max

Optional Disconnect

CUSTOMS UNION DATA PLATE

A O

C

For Disconnect option only (Main Electrical M25)

Standard 2" FNPT

Optional 2" MNPT

Optional 2" 300# RF

H

J

D

G

F

Hazardous Heaters

DATE HEAT WHEN YOU NEED IT

D

M

N

Heater Size	12	16	20	24	30
Dim.	Inches (mm)	Inches (mm)	Inches (mm)	Inches (mm)	Inches (mm)
A	12.60 (320)	15.51 (394)	19.49 (495)	23.46 (596)	29.53 (750)
B	4.02 (102)	4.02 (102)	4.02 (102)	4.65 (118)	5.71 (145)
C	1.85 (47)	2.38 (60.5)	2.40 (61)	2.40 (61)	2.40 (61)
D	16.30 (414)	20.28 (515)	24.29 (617)	28.27 (718)	34.33 (872)
E	9.76 (248)	9.76 (248)	10.51 (267)	11.81 (300)	13.78 (350)
F	6.77 (172)	5.77 (146.5)	5.75 (146)	6.69 (170)	7.48 (190)
G	2 holes only	1.75 (44.5)	2.50 (63.5)	2.76 (70)	3.15 (80)
H	2.64 (67)	2.64 (67)	3.62 (92)	4.29 (109)	4.37 (111)
I	21.37 (543)	21.37 (543)	21.67 (550)	23.42 (595)	25.39 (645)
J	11.02 (280)	15.00 (381)	17.00 (432)	19.69 (500)	25.59 (650)
K	1.38 (35)	1.38 (35)	1.38 (35)	1.38 (35)	1.38 (35)
L	25.37 (644)	25.37 (644)	25.37 (644)	23.42 (596)	29.39 (746)
M	22.49 (571)	26.47 (672)	30.48 (774)	34.46 (875)	40.50 (1029)
N	24.81 (630)	28.79 (731)	32.80 (833)	36.72 (932)	42.84 (1088)
O	19.07 (484)	21.98 (558)	25.96 (659)	29.93 (760)	36.00 (914)

General Specifications

Heater Hazardous Location Ratings: Customs Union (Without Disconnect)	1 Ex d e IIB (T4 - T2) Gb X T _a = -50°C to +40°C, IP55 (Three Phase) T _a = -35°C to +40°C, IP55 (Single Phase)
Heater Hazardous Location Ratings: Customs Union (With Disconnect)	1 Ex d e IIB (T4 - T2) Gb X T _a = -45°C to +40°C, IP55 (Three Phase) T _a = -35°C to +40°C, IP55 (Single Phase)
Maximum Allowed Fluid Temperature as per the T-Code (T4 - T2)	T4 : Liquid or VaporNo more than 126°C T3 : Liquid or VaporNo more than 190°C T2 : VaporNo more than 241°C T2 : LiquidNo more than 288°C
Approvals	CUTR 012 C of C: TC RU C-CA.BH02.B.00612 (hazardous location) CUTR 010 D of C: EAЭC N RU Д-CA.БЛ08.В.03691 (machine safety) CUTR 032 D of C: EAЭC N RU Д-CA.БЛ08.В.03692 (pressure equipment)
Heater Core Maximum Pressure Rating	SRH2 = 150 psig (1034 kPa). HUH2 = 400 psig (2758 kPa).
Heater Core Maximum Design Temp.	550 °F (288°C).
Heater Core Minimum Design Metal Temp.	-20°F (-29°C).
Cabinet Material	14-gauge (0.075") (1.9 mm) steel. Epoxy/polyester powder coated.
Louver Blades	Anodized extruded aluminum.
Fan	Spark-resistant aluminum
Fan Shroud	Spark-resistant aluminum
Fan Guard	Split design with close wire spacing. A Ø3/8" (9.5 mm) probe will not enter.
Motor Drive	Thermally protected permanently lubricated ball bearing type.
Mounting Holes	5/8"-11 UNC: 4 holes at top of heater (12" model has only 2 holes).
Fluid Connections	Standard: 2" NPT female inlet and outlet (configuration of fluid connection locations can be reversed by rotating the core). Other connection types are available (see model code chart).
Header Material	12 gauge (0.105")(2.7 mm) and 3/16" (4.8 mm) carbon steel plate conforming to ASME requirements.
Finned Tubes	5/8" (15.9 mm) outside diameter [16-gauge, 0.065" (1.6 mm) wall thickness] carbon steel tubes with 1-1/2" (38.1 mm) outside diameter copper-free, L-foot, tension-wound aluminum fins @ 10 fins per inch.

Weights - Customs Union Heaters

SRH2 Heaters		12"	16"	20"	24"	30"
Net Weight (no options)	Lbs (kg)	126 (57.1)	144 (65.3)	185 (83.9)	311 (141.1)	288 (130.6)
Shipping Weight (no options)	Lbs (kg)	180 (81.6)	204 (92.5)	251 (113.8)	384 (174.2)	375 (170.1)
with disconnect (add)	Lbs (kg)	8 (3.6)	8 (3.6)	8 (3.6)	10 (4.5)	10 (4.5)
with 2" NPT nipples (add)	Lbs (kg)	1 (0.4)	1 (0.4)	1 (0.4)	1 (0.4)	1 (0.4)
with flanges & nipples (add)	Lbs (kg)	14 (6.3)	14 (6.3)	14 (6.3)	14 (6.3)	14 (6.3)
HUH2 Heaters		12"	16"	20"	24"	30"
Net Weight (no options)	Lbs (kg)	126 (57.1)	144 (65.3)	185 (83.9)	311 (141.1)	295 (133.8)
Shipping Weight (no options)	Lbs (kg)	180 (81.6)	204 (92.5)	251 (113.8)	384 (174.2)	382 (173.3)
with disconnect (add)	Lbs (kg)	8 (3.6)	8 (3.6)	8 (3.6)	10 (4.5)	10 (4.5)
with 2" NPT nipples (add)	Lbs (kg)	1 (0.4)	1 (0.4)	1 (0.4)	1 (0.4)	1 (0.4)
with flanges & nipples (add)	Lbs (kg)	14 (6.3)	14 (6.3)	14 (6.3)	14 (6.3)	14 (6.3)

Specifications By Model Size - Customs Union Heaters - 50Hz

Model		12"	16"	20"	24"	30"
Fan Diameter	inch (mm)	12 (304.8)	16 (406.4)	20 (508.0)	24 (609.6)	30 (762.0)
Air Delivery*	CFM (m ³ /hr)	908 (1543)	1375 (2336)	2500 (4247)	3167 (5380)	4583 (7787)
Approx. Air Velocity*	FPM (m/s)	1088 (5.5)	926 (4.7)	1091 (5.5)	948 (4.8)	888 (4.5)
Air Throw* @ 15 psi steam	ft (m)	38 (11.4)	54 (16.5)	58 (17.7)	67 (20.3)	71 (21.6)
Motor Power	HP (Watts)	1/2 (373)	1/2 (373)	1/2 (373)	1/2 (373)	3/4 (559)
Rec. Min. Mounting Height	ft (m)	7.5 (2.3)	7.5 (2.3)	7.5 (2.3)	7.5 (2.3)	7.5 (2.3)

* At 70°F (21°C), 50 Hz and sea level.

Specifications By Model Size - Customs Union Heaters - 60Hz

Model		12"	16"	20"	24"	30"
Fan Diameter	inch (mm)	12 (304.8)	16 (406.4)	20 (508.0)	24 (609.6)	30 (762.0)
Air Delivery*	CFM (m ³ /hr)	1090 (1852)	1650 (2803)	3000 (5097)	3800 (6456)	5500 (9344)
Approx. Air Velocity*	FPM (m/s)	1305 (6.6)	1111 (5.6)	1309 (6.6)	1138 (5.8)	1066 (5.4)
Air Throw* @ 15 psi steam	ft (m)	45 (13.7)	65 (19.8)	70 (21.3)	80(24.4)	85 (25.9)
Motor Power	HP (Watts)	1/2 (373)	1/2 (373)	1/2 (373)	1/2 (373)	3/4 (559)
Rec. Min. Mounting Height	ft (m)	7.5 (2.3)	7.5 (2.3)	7.5 (2.3)	7.5 (2.3)	7.5 (2.3)

* At 70°F (21°C), 60 Hz and sea level.

Noise Data By Model Size - Customs Union Heaters - 50Hz

Model		12"	16"	20"	24"	30"
Front of Heater (dBA)	3 feet	68	73	79	80	86
	10 feet	66	68	73	73	79
	15 feet	62	66	72	72	77
Rear of Heater (dBA)	3 feet	68	73	80	80	85
	10 feet	65	67	72	73	79
	15 feet	63	65	70	71	77

Noise Data By Model Size - Customs Union Heaters - 60Hz

Model		12"	16"	20"	24"	30"
Front of Heater (dBA)	3 feet	73	78	83	83	90
	10 feet	66	73	76	76	83
	15 feet	64	70	74	74	81
Rear of Heater (dBA)	3 feet	71	78	83	83	89
	10 feet	65	72	77	77	83
	15 feet	64	71	75	75	81

Conditions For Safe Use

1. Remove any dirt / dust from heater cabinet using a damp cloth to mitigate electrostatic charge build up.
2. Do not install the heater in an environment which could potentially cause an electrostatic charge build up on the cabinet (i.e. exposure to high pressure steam).
3. The heater core is NOT field repairable. All defective cores must be replaced with a factory supplied unit.
4. The motor is NOT field repairable. All defective motors must be replaced with a factory supplied or factory approved unit.
5. Flameproof joints are NOT field repairable. Any damaged enclosures/fittings will have to be replaced with factory approved units.
6. For any field repairs use only original factory installed fasteners or factory supplied replacement fasteners.

— WARNING! —

Read and follow the instructions in this manual. Failure to do so may result in injury.

1. Heater is to be transported in the factory supplied crate.
2. Heater is to be stored indoors in a clean dry environment.
3. Heater is to be installed and serviced only by qualified personnel and must adhere to all applicable codes.
4. Heater must be grounded to mitigate electrostatic discharge hazard. Internal and external earth points are provided.
5. Do not operate heater in ambient temperatures above 40°C (104°F).
6. Ensure the product certifications and ratings meet all the requirements for the installation.
7. Ensure all field wiring meets the certification requirements and has the correct 'type of protection'.
8. As per Customs Union Technical Regulations, SRH2 model heaters are certified for use with Group 1, Category 2 vapour and Group 2, Category 1 vapour, HUH2 model heaters are certified for use with Group 2, Category 2 vapour and Group 1, Category 2 liquid (see CUTR 032, tables 1, 2&3).
9. Ensure that the proper warning and safety systems are installed to protect the heater from overpressure.
10. Heater T-code is determined by the process fluid inside the core. Verify the heater T-code meets the hazardous location requirements for the installation.
11. Do not use if the heater core is damaged or leaking. Contact factory for a replacement core, the core is not field repairable.
12. Do not operate heater in atmospheres which are corrosive to aluminum or steel, unless it has been coated with a factory approved protective coating.
13. Heater must be kept clean. When operating in a dirty environment, regularly clean the fin tubes, fan, fan guard, fan shroud, motor, louvers, and cabinet. Refer to recommended maintenance procedures.
14. The minimum gap between the fan and fan shroud is to be maintained at all times. See installation and repair instructions for the minimum gap requirements.
15. Use factory supplied or approved replacement parts only.
16. Follow all local codes and regulations for the disposal of used or damaged parts or products.
17. A boiler water chemical treatment program is recommended to reduce / prevent corrosion in piping systems.

— WARNING! —

Read and follow the instructions in this manual. Failure to do so may result in injury.

Cable Entries

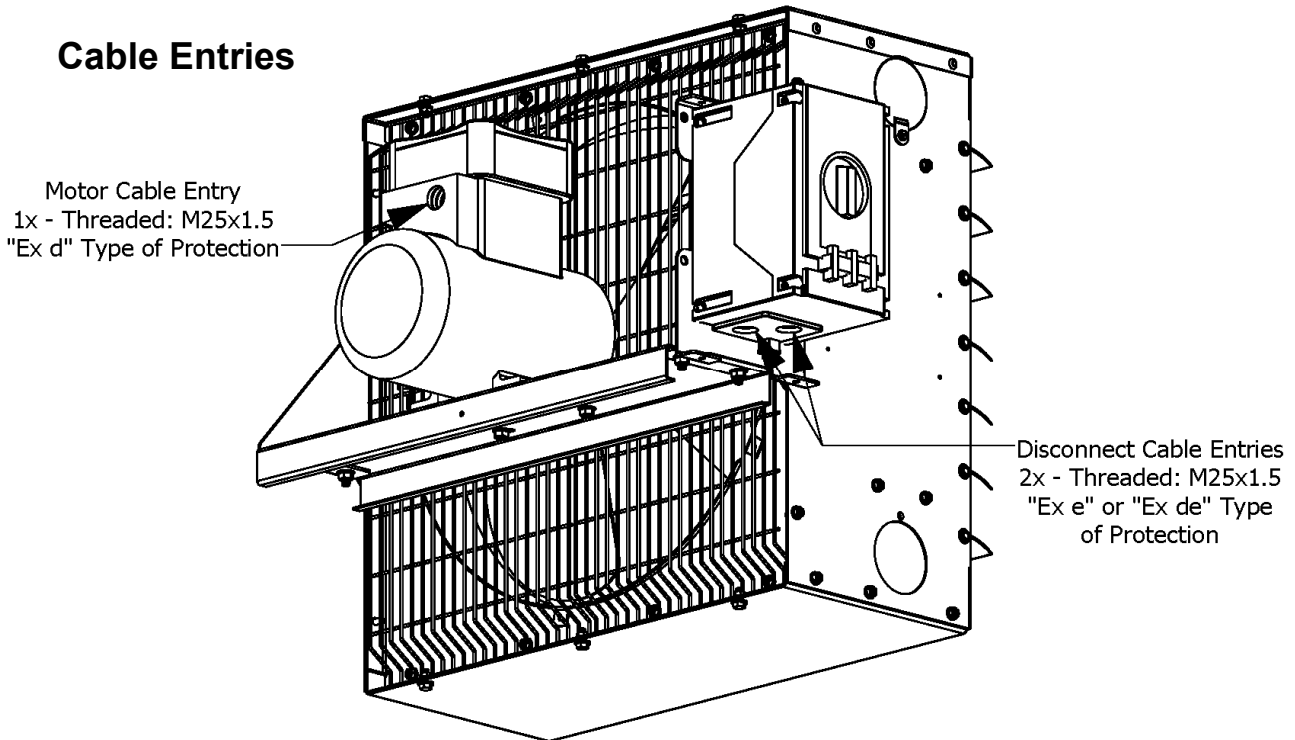

— ELECTRICAL INSTALLATION —

1. Heater is to be connected and serviced only by a qualified electrician experienced with hazardous location equipment. It is the responsibility of the installer to verify the safety and suitability of the installation.
2. **Explosion/Electric Shock Hazard.** Disconnect heater from power supply before opening enclosures or servicing heater. Do not open if an explosive atmosphere is present.
3. Use copper conductors only for supply wires and approved explosion-proof means of wiring during installation. Use minimum 90°C rated wire.
4. Field wiring connected to the motor requires "Ex d" certified components.
5. Field wiring connected to the disconnect switch requires "Ex e" or "Ex de" certified components.
6. Installation must include appropriate over-current protection devices as required by the applicable electrical code.
7. Confirm that the electrical power supply matches the name plate voltage, phase, amperage and frequency rating of the heater to be connected.
8. Supply voltage is to be within 5% of the data plate voltage
9. The heater requires adequate earthing. Internal and external earthing points are provided.
10. **All** unused threaded openings in enclosures must be fitted with threaded plugs approved for use in hazardous locations.
11. Ensure that all field wiring has adequate strain relief.
12. Ensure all cable gland and cable field wiring is appropriate for the hazardous location.
13. Before application of electrical power check all connections to ensure compliance with the wiring diagram and any code requirements. Remove any foreign objects from the electrical enclosure. Ensure all wire terminals are tight and not pinching the wire insulation. Reinstall cover tight and secure.
14. **On all three-phase heaters, it is necessary to verify that the fan rotation is correct** (counter clockwise when facing the rear of the heater). If air delivery is not from the front of the heater, reverse any two power supply leads.

— INSTALLATION —

These instructions are to be used as a general guideline only.

Location

Please follow guidelines below for optimum heating results:

1. Do not install heaters such that airflow is blocked or impeded by equipment or walls.
2. For occupant comfort, position heaters so that air discharge is directed across areas of highest heat loss, such as doors, windows, and outside walls.
3. For large areas, arrange heaters such that the air discharge of one heater is directed towards the inlet of the next heater. This sets up a rotational airflow with air circulation in the central area of the building.
4. For equipment freeze protection, direct air discharge at required equipment.
5. For large workshops or warehouses it may be acceptable to use fewer, but larger heaters.
6. Do not direct air discharge towards a room thermostat.
7. Heater inlet and outlet coupling connection locations can be reversed in the field by removing the core, rotating it 180 degrees, and then re-installing it. Cabinet plugs can then be repositioned.

Mounting

1. A variety of mounting brackets are available from the factory to aid in installation.
2. The heater is designed to be installed in an upright and level position. While it may be installed in other positions, for steam service, the inlet must be above the outlet and the bottom of the heat exchanger must drain towards the outlet.
3. Heaters are designed to be suspended from the top of the cabinet using either two or four 5/8"–11 UNC bolts or threaded rod.
4. It is essential that adequate structural support be provided for installation. The mounting structure must be strong enough to support the heaters weight, provide sufficient stiffness to prevent excessive vibration, and withstand all probable abusive situations such as transportable installations where truck off-loading impacts, etc. may occur.

Mounting Heights and Clearances

1. To ensure that warm air reaches the floor, heaters are usually mounted 7-1/2 ft. (2.3m) to 12 ft. (3.6 m) above the floor. Heaters may be mounted at higher elevations and still provide warm air at floor level however, the maximum mounting elevation at which this occurs depends on location and operational conditions.
2. Louvers may be adjusted to provide greater downward deflection of the discharge air. However, it is recommended that louvers not be set <15° from the closed position.

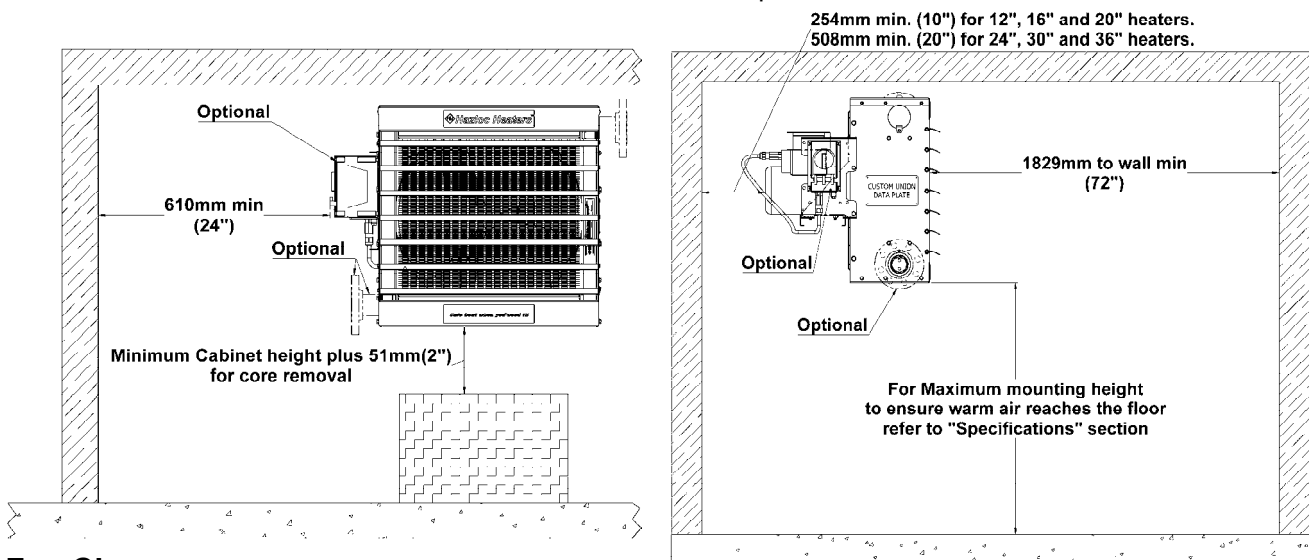

Fan Clearance

1. Verify the minimum required clearance between fan blades / fan shroud and the fan blades / fan guard prior to heater power up.

Heater Size	12"	16"	20"	24"	30"
Min Clearance	2.0 mm	2.0 mm	2.5 mm	3.0 mm	3.8 mm

— PIPING SUGGESTIONS —
Suggested piping arrangements only, refer to local codes for more detail

Steam Systems

- Corrosion in steam and condensate system piping & unit heaters occurs as a result of the formation of acids within the steam and condensate. To prevent corrosion a boiler water chemical treatment program is recommended.
- Install heaters using proper piping practices.
- Do not use with fluids corrosive to steel.
- Use a properly sized steam trap. Inspect traps regularly under your routine maintenance program.
- In horizontal pipe runs, use eccentric reducers only.
- For steam service use only single-pass heaters.

Note: Heater inlet and outlet coupling connection locations can be reversed in the field by rotating the core.

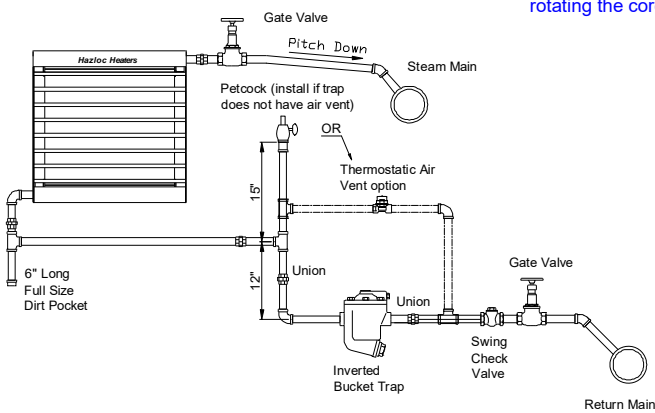

Unit Heater Connection for High Pressure Steam

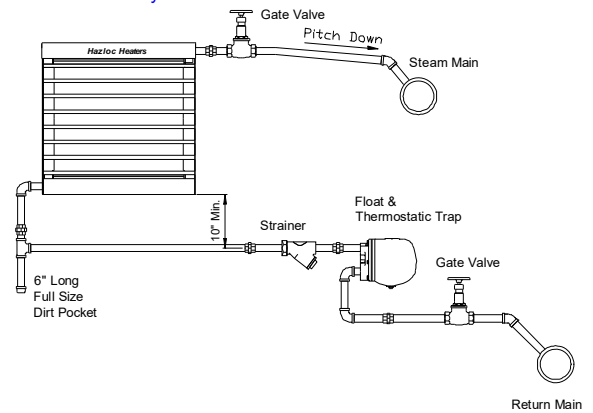

**Unit Heater Connection for Low Pressure Steam
 - Open Gravity or Vacuum Return System**

Fluid Systems

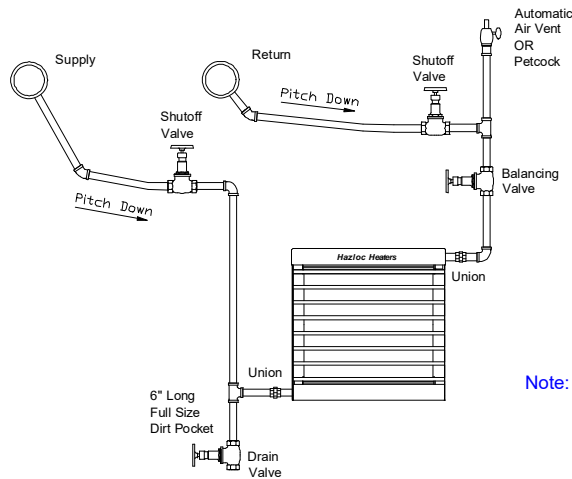

Unit Heater Connections to Overhead Fluid Mains

- Install using proper piping practices.
- Do not use with fluids corrosive to steel.

Note: Heater inlet and outlet coupling connection locations can be reversed in the field by rotating the core.

— Piping Practices —

1. Steam unit heaters condense steam rapidly, especially during warm-up periods. The return piping must be planned to keep the heat-exchanger's core free of condensate during periods of maximum heat output, and steam piping must be able to carry a full supply of steam to the unit heater to take the place of condensed steam. Adequate pipe size is especially important when a unit heater fan is operated under on-off control because the condensate rate fluctuates rapidly.
2. Heater is to be connected and serviced only by qualified personnel. For additional piping information refer to local codes.
3. Eliminate pipe stress by adequately supporting all piping. Do not rely on heater to support piping.
4. Take off all branch lines from the top of steam mains, preferably at a 45° angle, although vertical 90° connections are acceptable.
5. Pipe the branch supply line into the steam unit heater's inlet at the top and the return branch line from the outlet at the bottom. **The heater's inlet and outlet coupling connections can be reversed in the field by rotating the heat-exchanger core.** Refer to Page 11, **Heat-Exchanger Core Assembly Replacement.**
6. In steam systems, the branch from the supply main to the heater must pitch down towards the main and be connected to its top in order to prevent condensate in the main from draining through the heater. In long branch lines, a drip trap may be needed.
7. Allow for pipe expansion to prevent excessive strain on the unit heater's heat-exchanger core.
8. The return piping from steam unit heaters should provide a minimum drop of 10" (254 mm) below the heater so that the pressure of water required to overcome resistances of check valves, traps, and strainers will not cause condensate to remain in the heater.
9. In steam systems, where horizontal piping must be reduced in size, use eccentric reducers that permit the continuance of uniform pitch along the bottom of piping (in downward pitched systems). Avoid using concentric reducers on horizontal piping, because they can cause water hammer.
10. Installing dirt pockets at the outlet of unit heaters and strainers with 0.063 in. (2 mm) perforations to prevent rapid plugging are essential to trap dirt and scale that might affect the operation of check valves and traps. Strainers should always be installed in the steam supply line if the heater is valve controlled.
11. In steam or hot water systems, rapid air removal is required because entrained air is a cause of corrosion. Hot water systems should be equipped with suitable air vent valves for rapid and complete air removal at high points, at the top of each unit heater, and ends of both supply and return mains. Proper air venting for steam systems can be achieved by use of a steam trap with an internal air vent.
12. Steam traps must be located below the outlet of the unit heater. Consult the trap manufacturer for specific recommendations. Each steam unit heater should be provided with a trap of sufficient size and capacity to pass a minimum of twice the normal amount of condensation released by the unit at the minimum differential pressure in the system. Trap capacity is based on the pressure differential between supply and return mains. Steam systems should be equipped with a float and thermostatic trap or inverted bucket trap with an air bypass.
13. If the condensate return line is above the heater outlet or is pressurized, install a check valve after the steam trap and a drain valve at the strainer to drain the system during the off season.
14. Install pipe unions and shut-off valves at connection points of each unit heater to allow maintenance or replacement of unit without shutting down and draining the entire system. For hot water systems include a balancing valve in return line for flow regulation. A drain valve should be provided below each unit heater to allow removal of water from the heat-exchanger core if located in an area subject to freezing.
15. Adequate air venting is required for low-pressure closed gravity systems. The vertical pipe connection to the air vent should be at least 3/4" NPT to allow water to separate from the air passing to the vent. If thermostatic instead of float-and-thermostatic traps are used in vacuum systems, a cooling leg must be installed ahead of the trap.
16. In high-pressure systems, it is customary to continuously vent the air through a petcock unless the steam trap has a provision for venting air. Most high-pressure return mains terminate in flash tanks that are vented to the atmosphere. When possible, pressure reducing valves should be installed to permit operation of the heaters at low pressure. Steam traps must be suitable for the operating pressure encountered.
17. On steam systems where the steam supply to the unit heater is modulated or controlled by a motorized valve, a vacuum breaker should be installed between the unit outlet and a float and thermostatic trap.

— Warning —
Wiring should only be connected by qualified personnel.

— Electrical Wiring of Heater and Remote Mount Thermostats —

Wiring diagrams are located either on the motor or on the optional disconnect switch. On all three-phase heater motors, it is necessary to verify that the fan rotation is correct (counter clockwise when facing the rear of the heater). If air delivery is not from the front of the heater, reverse any two power supply leads.

⊕ “External Earth” points are provided on the motor and the heater side panel. ⊕

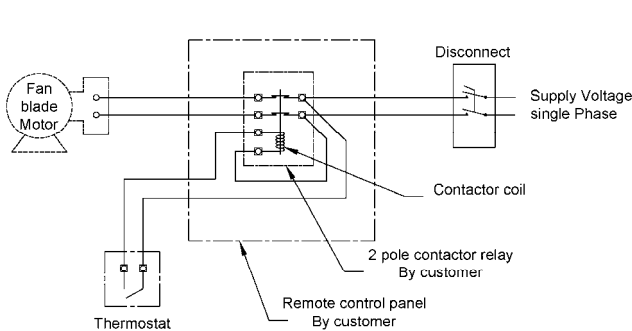

**Thermostatic Control for High motor current
Single phase motors**

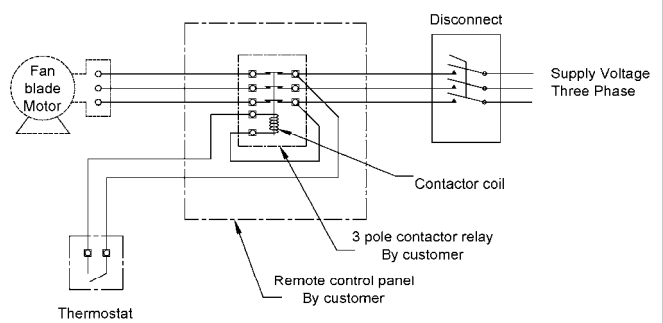

**Thermostatic Control for Low voltage
Three phase motors**

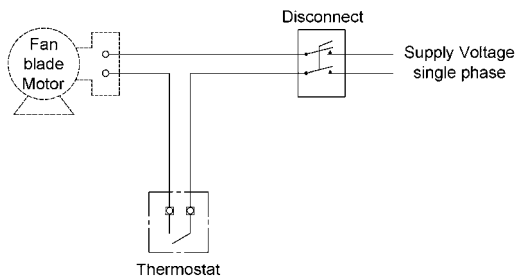

**Thermostatic Control for Low motor current
Single phase motors**

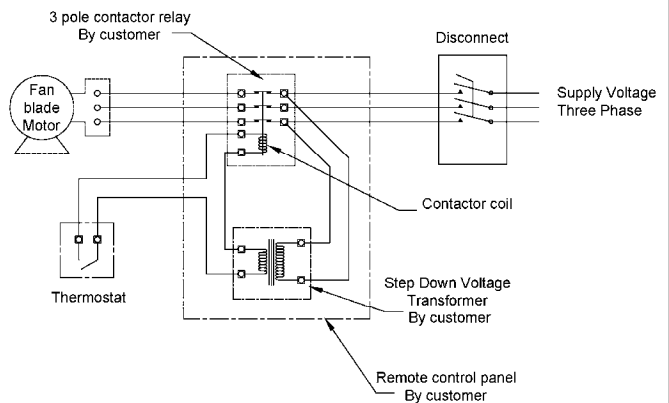

**Thermostatic Control for High voltage
Three phase motors**

BTX - Bi-metal Explosion Proof Thermostat

Electrical Ratings

- Voltage free contacts, 50/60Hz
- 22 Amp up to 480VAC (resistive)
- 125VAC @ 0.17kW (1/4HP)
- 125VAC @ 0.35kW (1/2HP)
- 250VAC @ 0.55kW (3/4HP)
- 250VAC @ 0.75kW (1HP)

PILOT DUTY Ratings

- 490 VA @ 125VAC
- 800 VA @ 250VAC

— WARNING! —

Heater should only be service by qualified personnel.

Disconnect unit heater from power supply before starting any service or repair work.
Follow all lockout / tag out procedures.
Failure to follow these procedures may result in injury.

— Repair and Replacement —

Heat-Exchanger Core Assembly Replacement

1. Heat-exchanger core assemblies are heavy and replacement requires two people for safety reasons.
2. It is not necessary to dismount unit heater from its support structures to remove the heat-exchanger core assembly. However, it may be advisable in some instances to allow for core assembly removal at ground or bench level.
3. Remove the bottom heater cabinet cover which is attached with 6 screws and 3 bolts.
4. Support the heat exchanger core assembly, then remove the 4 core bolts on each side of the cabinet.
5. Lower the core assembly from heater.
6. Reverse the procedure to install replacement core and tighten 4 core bolts to 10 N-m (90 in-lbs) torque, bottom panel screws to 3 N-m (28 in-lbs), and fan panel bolts to 11 N-m (100 in-lbs).

Note: Heater inlet and outlet coupling connection locations can be reversed in the field by removing the core, rotating it 180 degrees, and then re-installing it. Cabinet plugs can then be repositioned.

Torque Settings		
Item	(in-lbs)	(N-m)
Fan blade set screw	150	17
5/16 - 18 UNC motor nuts	250	28
5/16 - 18 UNC motor mount bolts	250	28
1/4 - 20 UNC fan panel bolts	100	11
1/4 - 20 UNC fan guard self tapping screws	100	11
1/4 - 20 UNC core bolts	90	10
#10 - 24 UNC bottom panel & louver blade screws	28	3

Fan, Fan Guard or Motor Replacement

1. For replacement of fan or fan guard remove the 4 bolts holding motor to the motor mount.
2. Detach two-piece fan guard assembly by removing top and bottom screws that attach the fan guard to the cabinet.
3. Remove fan guard pieces through top or bottom. Due to stiffness of fan guards, you may need to remove outer two top or bottom bolts that attach the fan panel to the top or bottom cabinet panels to provide sufficient clearance.
4. Lift the motor and fan assembly off the motor mount.
5. Loosen fan hub screw and remove fan blade from motor shaft.
6. To reassemble, position fan on motor shaft with end of shaft even with face of hub. Ensure the set screw is facing towards motor and lined up perpendicular to factory-ground flat on motor shaft. This flat is our "Easy-Off" fan blade replacement feature and only comes on motors purchased from Hazloc Heaters. Tighten set screw to 17 N-m (150 in-lbs) torque.
7. Place motor and fan assembly onto motor mount and fasten the two-piece fan guards to the cabinet.
8. Center fan in the fan-shroud opening. The gap between the fan blades and fan shroud should be even for all fan blades. Ensure the minimum gap is maintained for all blades. See page 7 for minimum gap values.
9. Bolt motor to motor mount, tighten nuts to 28 N-m (250 in-lbs) torque. Manually spin the fan blade to ensure it rotates freely before reconnecting heater to power supply. Fan must rotate counterclockwise when viewed from rear of heater.

— Parts List —

***** Please have heater model & serial number available before calling *****

12 inch to 30 inch models

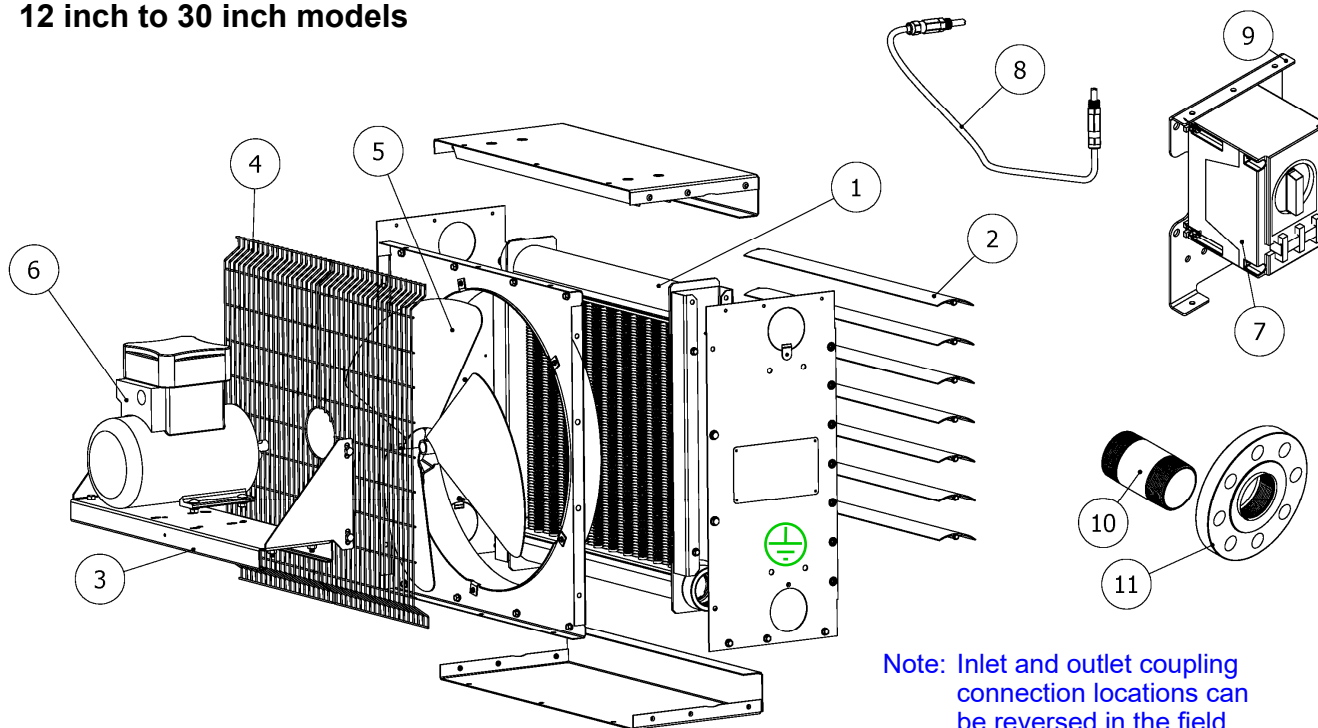

Note: Inlet and outlet coupling connection locations can be reversed in the field by rotating the core.

12 inch to 30 inch models

Item No.	Description	12 inch	16 inch	20 inch	24 inch	30 inch
		Part Number	Part Number	Part Number	Part Number	Part Number
*** Please have heater model & serial number available before calling ***						
1	Core Kit	Contact factory with heater model, size, number of passes and connection type Part #'s 1119 thru 1139				
2	Louver Blade kit	1145	1146	1147	1148	1149
3	Motor Mount Kit	1151	1152	1153	1154	1155
4	Fan Guard Kit	1157	1158	1159	1160	1161
5	Fan - 19mm hub	1164	1166	1168	1170	1172
6	Motor Kit - 19mm shaft	Specify motor voltage, phase, frequency, horsepower and type of enclosure (general purpose or explosion-proof)				
7	Disconnect, 20 Amp	1097				
8	Disconnect Cable Kit, Three Phase	1174	1174	1174	1175	1175
8	Disconnect Cable Kit, Single Phase	1248	1248	1248	1249	1249
9	Disconnect Bracket Kit	1054				
10	Thread-on 2 inch MNPT, Sch. 80 Nipple	1176				
11	Thread-on 2 inch FNPT, 300# Raised Face Flange	1177				

*All replacement part kits include fasteners

— WARNING! —

Heater should only be service by qualified personnel.

Disconnect unit heater from power supply before starting any service or repair work.
Follow all lockout / tag out procedures.
Failure to follow these procedures may result in injury.

— Maintenance Program —

Regular inspection, based on a schedule determined by the amount of dirt in the atmosphere, assures maximum operating economy and heating capacity.

Annual Inspection (before each heating season)

1. Check all terminal connections, electrical conductors, glands and cables for damage, looseness, defects, fraying, etc. and replace or tighten where applicable.
2. Check for fluid leakage from heat-exchanger core. If fluid leakage occurs, remove heater from service and have the heat-exchanger core replaced by a factory replacement unit. Refer to "Repair and Replacement" section for complete details. **Note: This heat-exchanger core is not field repairable.**
3. Check electrical junction box. Inside of enclosure must be clean, dry, and free from any foreign materials. The cover must also be completely on and tight.
4. Check motor shaft bearing play. Replace motor if play is excessive or if motor does not run quietly and smoothly. Motor bearings are permanently lubricated.
5. Check fan. Replace immediately if cracked or damaged. Check the gap between the fan and fan shroud meets the minimum spacing requirement.
6. Check louvers. Louver screws should be tight. Louvers are not to be set <15° of the closed position.
7. Check the tightness of all hardware. All nuts and bolts, including mounting hardware, must be tightened to torque settings on Page 11.
8. Turn heater motor on for a minimum of 10 minutes. Check for air exiting heater through louvers and smooth running of the motor and fan assembly.

Periodic Maintenance (before and as required during heating season)

1. Clean the following (remove dust using compressed air):

- Finned tubes
- Fan
- Fan Shroud
- Fan Guard
- Motor
- Louvers
- Cabinet



2. Check the following:

- Motor / fan assembly for smooth and quiet operation.
- Louvers for proper angle and tightness.
- Electrical covers are secure.
- Gap between the fan blade / fan shroud and the fan blade / fan guard meet the minimum spacing requirement (see page 7 for minimum values).

HEATER MAINTENANCE RECORD

Heater Model: _____ Serial No.: _____

Date of Maintenance	Performed By	Maintenance Performed

HEATER MAINTENANCE RECORD

Heater Model: _____ Serial No.: _____

Date of Maintenance	Performed By	Maintenance Performed

Limited 18-Month Warranty

Hazloc Heaters™ warrants all **SRH2 & HUH2** series of heat-exchanger unit heaters against defects in materials and workmanship under normal conditions of use for a period of eighteen (18) months from date of purchase based on the following terms:

1. The heater must not be modified in any way.
2. The heater must be stored, installed and used only in accordance with the owner's manual and attached data plate information.
3. Replacement parts will be provided free of charge as necessary to restore any unit to normal operating condition, provided that the defective parts be returned to us freight prepaid and that the replacement parts be accepted freight collect.
4. The complete heater may be returned to our manufacturing plant for repair or replacement (at our discretion), freight charges prepaid.
5. Components damaged by contamination from dirt, dust, etc. or corrosion will not be considered as defects.
6. This warranty shall be limited to the actual equipment involved and, under no circumstances, shall include or extend to installation or removal costs, or to consequential damages or losses.

Exclusive Representative

For additional information or to order contact Canam Pipe & Supply with the link below.



canam@canamservices.com

www.canamservices.com
