



INTERNAL CUTTERS

Overview

Internal Cutters are used to cut tubing, casing, and drill pipe and may also be run on sucker rods and macaroni strings. These mechanically operated cutters permit alternate sizes of pipe to be cut when redressing an assembly. All Internal Cutters feature a device that permits the operator to set the cutter to any depth, release the tool, and reset it to another depth without coming out of the hole.

Each cutter is designed to cut a given range of tubing when dressed with correctly sized components. Collar finders are also available for each size.

Construction

Internal Cutters consist of either a wiper block or drag spring assembly for setting in the pipe. Slips and a cone assembly anchor the cutter. A main spring aids in maintaining uniform feed to the knives. Knife blocks drive the knives upward and outward to engage the pipe. Pre-cision ground knives easily cut the pipe.

Operation

After the cutter has been lowered to desired cutting depth, anchor the cutter by slowly rotating while continuing to lower. This will set the slips and allow the mandrel to travel down under the knife blocks. The knife blocks will force the knives up and outward to engage the pipe so the cut can be made. Apply minimum weight while slow rotation (8 to 18 rpm) of the work string is continued. Cutting is best accomplished by slacking off in increments while making the cut. Lack of reverse torque and free rotation of the work string will indicate that the cut has been made.

When ordering, please specify:

- (1) Name and number of assembly or part
- (2) Size of pipe to cut

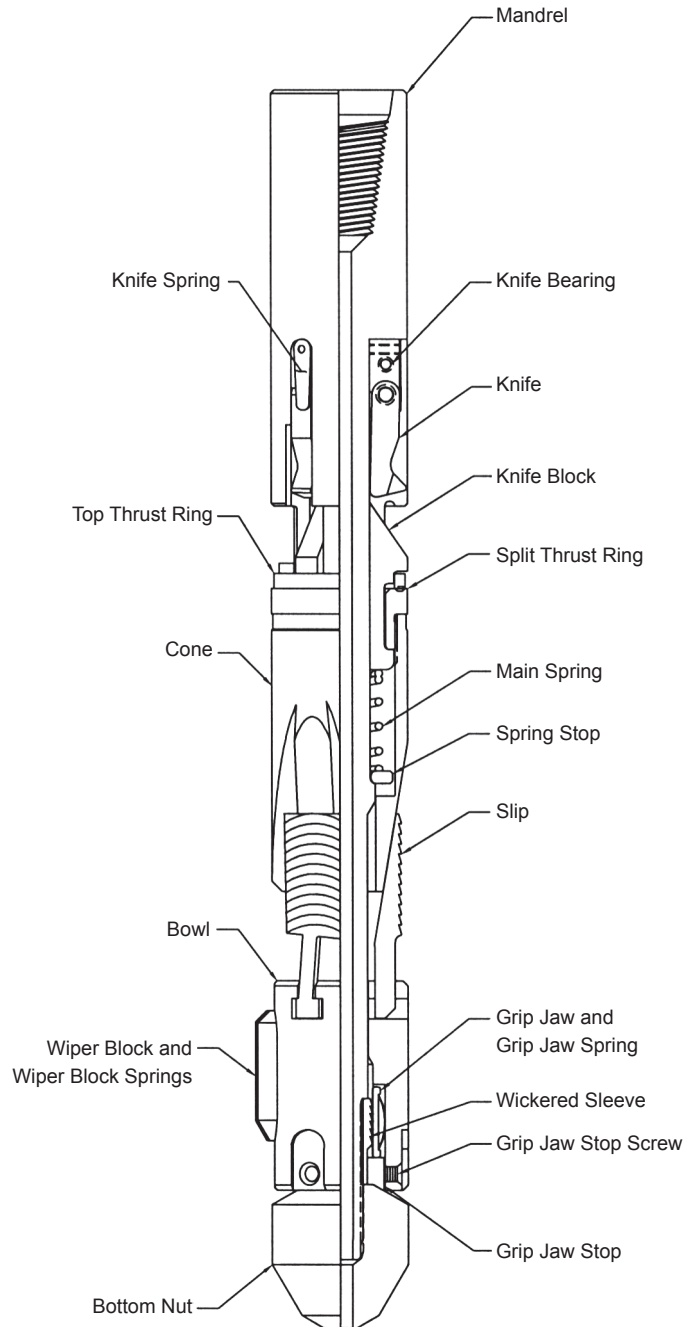



Internal Cutters

INTERNAL CUTTERS

PIPE SIZE TO CUT		1.900 Tbg	2-3/8 Tbg	2-7/8 Tbg	2-7/8 Tbg	3-1/2 Tbg	4-1/2 FH DP	4-1/2 IF DP
CAN BE DRESSED FOR		...	2-7/8 IF DP	...	3-1/2 IF DP	4 Tub	4-1/2 IF DP	4-1/2, 4-3/4,
			2-7/8 Tbg			4-1/2 Tbg	4-1/2 Csg	5 & 5-1/2 Csg
MINIMUM CUTTER O.D.		1-1/2	1-13/16	2-1/4	2-1/4	2-5/8	2-1/2	3-3/8
STANDARD ASSEMBLY		Drag Spring	Drag Spring	Drag Spring	Drag Spring	Wiper Block	Drag Spring	Wiper Block
COMPLETE ASSEMBLY		409-000	409-002	409-003	409-004	409-005	409-006	409-007
Consists of:	Bowen No.	25940	2174	8505	9176	8570	9465	8844
MANDREL		Q1000	Q1002	Q1003	Q1004	Q1005	Q1006	Q1007
	Bowen No.	25941	2175	8506	9177	8571	9466	8845
KNIFE BEARING		Q2000	Q2002	Q2002	Q2004	Q2004	Q2004	Q2004
	Bowen No.	25942	8433	8433	8575	8575	8575	8575
	No. Req'd	3	3	3	3	3	3	3
KNIFE SPRING SCREW		Q3000	Q3002	Q3002	Q3002	Q3002	Q3002	Q3002
	Bowen No.	13834	8181	8181	8181	8181	8181	8181
	No. Req'd	3	3	3	3	3	3	3
KNIFE SPRING		Q4000	Q4002	Q4002	Q4004	Q4004	Q4004	Q4004
	Bowen No.	25959	8434	8434	8629	8629	8629	8629
	No. Req'd	3	3	3	3	3	3	3
KNIFE		Q5000	Q5002	Q5002	Q5004	Q5004	Q5006	Q5004
	Bowen No.	25943	8432	8432	8572	8572	6807	8572
	No. Req'd	3	3	3	3	3	3	3
KNIFE BEARING SCREW		Q6000	Q6002	Q6003	Q6004	Q6005	Q6005	Q6005
	Bowen No.	23501	8529	8567	9189	8576	8576	8576
	No. Req'd	3	3	3	3	3	3	3
KNIFE PIN		Q7000	Q7002	Q7002	Q7004	Q7004	Q7006	Q7004
	Bowen No.	25944	8501	8501	8573	8573	9467	8573
	No. Req'd	3	3	3	3	3	3	3
KNIFE PIN SCREW		AA9001	Q8002	Q8002	Q8004	Q8004	Q8002	Q8004
	Bowen No.	12484	8445	8445	8574	8574	8445	8574
	No. Req'd	3	3	3	3	3	3	3
KNIFE BLOCK		Q9000	Q9002	Q9003	Q9004	Q9004	Q9006	Q9007
	Bowen No.	25945	8436	8507	8580	8580	6809	8846
	No. Req'd	3	3	3	3	3	3	3
TOP THRUST		Q10000	Q10002	Q10003	Q10004	Q10005	Q10006	Q10007
	Bowen No.	25946	9421	8508	9422	8612	6810	8931
SPLIT THRUST		Q11000	Q11002	Q11003	Q11004	Q11005	Q11006	Q11007
	Bowen No.	25947	8438	8509	9179	8582	7496	8848

Notes:

- (1) Slip number Q15009 is for 5" 15-21# Csg, for 5" 11.5-13# Csg use Slip number Q40009.
- (2) Where both Wiper Block and Drag Spring parts are shown, the cutter can be ordered with either.
If not specified, Wiper Block parts will be furnished. (Note: Assemblies are priced differently.)

When ordering, please specify:

- (1) Name and number of assembly or part
- (2) Size of pipe to cut
- (3) Whether or not Bottom Nut is to be fitted for collar finder
- (4) Knives with carbide tips available upon request

Recommended Spare Parts:

- (1) 6 sets of Knives
- (2) 2 sets of Knife Pins
- (3) 6 sets of Knife Springs
- (4) 2 sets of Knife Spring Screws
- (5) 1 set of Slips
- (6) 1 set of Wiper Blocks
- (7) 1 set of Wiper Block Springs
- (8) 1 set of Wiper Block Screws
- (9) 1 set of Grip Jaws
- (10) 1 set of Grip Jaw Springs
- (11) 1 Wickered Sleeve
- (12) 1 set of Drag Springs
- (13) 1 set of Drag Springs Screws

PIPE SIZE TO CUT		1.900 Tbg	2-3/8 Tbg	2-7/8 Tbg	2-7/8 Tbg	3-1/2 Tbg	4-1/2 FH DP	4-1/2 IF DP
CAN BE DRESSED FOR		...	2-7/8 IF DP	...	3-1/2 IF DP	4 Tbg	4-1/2 IF DP	4-1/2, 4-3/4,
			2-7/8 Tbg			4-1/2 Tbg	4-1/2 Csg	5 & 5-1/2 Csg
MINIMUM CUTTER O.D.		1-1/2	1-13/16	2-1/4	2-1/4	2-5/8	2-1/2	3-3/8
STANDARD ASSEMBLY		Drag Spring	Drag Spring	Drag Spring	Drag Spring	Wiper Block	Drag Spring	Wiper Block
COMPLETE ASSEMBLY		409-000	409-002	409-003	409-004	409-005	409-006	409-007
	Bowen No.	25940	2174	8505	9176	8570	9465	8844
CONE	Logan Part No.	Q12000	Q12002	Q12003	Q12004	Q12005	Q12006	Q12007
	Bowen No.	25948	2177	8510	9180	8583	9468	8849
MAIN SPRING	Logan Part No.	Q13000	Q13002	Q13002	Q13004	Q13005	Q13006	Q13007
	Bowen No.	25949	8440	8440	9191	8584	9469	8850
SPRING STOP	Logan Part No.	Q14000	Q14002	Q14002	Q14004	Q14005	Q14005	Q14007
	Bowen No.	25950	8442	8442	9192	8585	8585	8851
SLIP	Logan Part No.	Q15000	Q15002	Q15003	Q15004	Q15005	Q15006	Q15007
	Bowen No.	25958	2180	4005	2178	8586	7201	8852
	No. Req'd	3	3	3	3	3	2	3
GRIP JAW SET	Logan Part No.	Q16000	Q16002	Q16002	Q16002	Q16005	Q16005	Q16005
	Bowen No.	25951	8443	8443	8443	8588	8588	8588
GRIP JAW SPRING	Logan Part No.	Q17000	Q17000	Q17000	Q17000	Q17005	Q17005	Q17005
	Bowen No.	8444	8444	8444	8444	8589	8589	8589
	No. Req'd	3	3	3	3	3	3	3
BOWL	Logan Part No.	Q18000	Q18002	Q18003	Q18004	Q18005	Q18006	Q18007
	Bowen No.	25952	8521	8520	9181	8597	9470	8853
GRIP JAW STOP	Logan Part No.	Q19000	Q19002	Q19003	Q19004	Q19005	Q19006	Q19005
	Bowen No.	25953	8446	8515	9182	8590	9471	8590
GRIP JAW STOP SCREW	Logan Part No.	Q20000	Q20002	Q20002	Q20002	Q20005	Q20005	Q20005
	Bowen No.	23096	62517	62517	62517	62681	62681	62681
	No. Req'd	3	3	3	3	3	3	3
WICKERED SLEEVE LONG	Logan Part No.	Q21000	Q21002	Q21002	Q21004	Q21005	Q21006	Q21005
	Bowen No.	25954	8568	8568	9185	8591	9475	8591
BOTTOM NUT	Logan Part No.	Q22000	Q22002	Q22003	Q22003	Q22005	Q22006	Q22007
	Bowen No.	25955	8565	8566	8566	8596	9476	8857

Notes:

(1) Slip number Q15009 is for 5" 15-21# Csg, for 5" 11.5-13# Csg use Slip number Q40009.

(2) Where both Wiper Block and Drag Spring parts are shown, the cutter can be ordered with either.

If not specified, Wiper Block parts will be furnished. (Note: Assemblies are priced differently.)

When ordering, please specify:

- (1) Name and number of assembly or part
- (2) Size of pipe to cut
- (3) Whether or not Bottom Nut is to be fitted for collar finder
- (4) Knives with carbide tips available upon request

Recommended Spare Parts:

- | | |
|-----------------------------------|-----------------------------------|
| (1) 6 sets of Knives | (8) 1 set of Wiper Block Screws |
| (2) 2 sets of Knife Pins | (9) 1 set of Grip Jaws |
| (3) 6 sets of Knife Springs | (10) 1 set of Grip Jaw Springs |
| (4) 2 sets of Knife Spring Screws | (11) 1 Wickered Sleeve |
| (5) 1 set of Slips | (12) 1 set of Drag Springs |
| (6) 1 set of Wiper Blocks | (13) 1 set of Drag Springs Screws |
| (7) 1 set of Wiper Block Springs | |

INTERNAL CUTTERS

PIPE SIZE TO CUT		1.900 Tbg	2-3/8 Tbg	2-7/8 Tbg	2-7/8 Tbg	3-1/2 Tbg	4-1/2 FH DP	4-1/2 IF DP
CAN BE DRESSED FOR		...	2-7/8 IF DP	...	3-1/2 IF DP	4 Tbg	4-1/2 IF DP	4-1/2, 4-3/4,
			2-7/8 Tbg			4-1/2 Tbg	4-1/2 Csg	5 & 5-1/2 Csg
MINIMUM CUTTER O.D.		1-1/2	1-13/16	2-1/4	2-1/4	2-5/8	2-1/2	3-3/8
STANDARD ASSEMBLY		Drag Spring	Drag Spring	Drag Spring	Drag Spring	Wiper Block	Drag Spring	Wiper Block
COMPLETE ASSEMBLY	Logan Part No.	409-000	409-002	409-003	409-004	409-005	409-006	409-007
	Bowen No.	25940	2174	8505	9176	8570	9465	8844
WIPER BLOCK	Logan Part No.	Q23005	...	Q23007
	Bowen No.	8598	...	8854
	No. Req'd	3	...	3
WIPER BLOCK SPRING	Logan Part No.	Q24005	...	Q24007
	Bowen No.	8599	...	8863
	No. Req'd	9	...	9
WIPER BLOCK SCREW	Logan Part No.	Q25005	...	Q25005
	Bowen No.	8856	...	8856
	No. Req'd	6	...	6
BOWL DRAG SPRING TYPE	Logan Part No.
	Bowen No.
MANDREL EXTENSION	Logan Part No.	Q27004	Q27005	Q27006	Q27005
	Bowen No.	9183	8595	9472	8595
DRAG SPRING	Logan Part No.	Q28000	Q28002	Q28002	Q28002	Q28005	Q28005	Q28005
	Bowen No.	25956	8569	8569	8569	8592	8592	8592
	No. Req'd	3	3	3	3	3	3	3
DRAG SPRING RING	Logan Part No.	Q29000	Q29002	Q29003	Q29003	Q29005	Q29006	Q29007
	Bowen No.	25957	8500	8518	8518	8594	9473	8855
DRAG SPRING SCREW	Logan Part No.	Q20000	Q20002	Q20002	Q20002	Q30005	Q20005	AK6004
	Bowen No.	23096	62517	62517	62517	62734	62681	8593
	No. Req'd	6	6	6	6	6	6	6
WICKERED SLEEVE SHORT	Logan Part No.	...	Q21002	Q31003
	Bowen No.	...	8568	8564
DRAG SPRING SHORT	Logan Part No.	Q32003
	Bowen No.	8449
	No. Req'd	3
ROD KNIFE	Logan Part No.	Q33003	Q33003
	Bowen No.	9423	9423

Logan Oil Tools reserves the right to change or discontinue designs without notice.

Notes:

- (1) Slip number Q15009 is for 5" 15-21# Csg, for 5" 11.5-13# Csg use Slip number Q40009.
- (2) Where both Wiper Block and Drag Spring parts are shown, the cutter can be ordered with either. If not specified, Wiper Block parts will be furnished. (Note: Assemblies are priced differently.)

When ordering, please specify:

- (1) Name and number of assembly or part
- (2) Size of pipe to cut
- (3) Whether or not Bottom Nut is to be fitted for collar finder
- (4) Knives with carbide tips available upon request

Recommended Spare Parts:

- (1) 6 sets of Knives
- (2) 2 sets of Knife Pins
- (3) 6 sets of Knife Springs
- (4) 2 sets of Knife Spring Screws
- (5) 1 set of Slips
- (6) 1 set of Wiper Blocks
- (7) 1 set of Wiper Block Springs
- (8) 1 set of Wiper Block Screws
- (9) 1 set of Grip Jaws
- (10) 1 set of Grip Jaw Springs
- (11) 1 Wickered Sleeve
- (12) 1 set of Drag Springs
- (13) 1 set of Drag Springs Screws

INTERNAL CUTTERS

PIPE SIZE TO CUT		1.900 Tbg	2-3/8 Tbg	2-7/8 Tbg	2-7/8 Tbg	3-1/2 Tbg	4-1/2 FH DP	4 1/2 IF DP
CAN BE DRESSED FOR		...	2-7/8 IF DP 2-7/8 Tbg	...	3-1/2 IF DP	4-Tbg 4-1/2 Tbg	4-1/2 IF DP 4-1/2 Csg	4-1/2, 4-3/4, 5 & 5-1/2 Csg
MINIMUM CUTTER O.D.		1-1/2	1-13/16	2-1/4	2-1/4	2-5/8	2-1/2	3-3/8
STANDARD ASSEMBLY		Drag Spring	Drag Spring	Drag Spring	Drag Spring	Wiper Block	Drag Spring	Wiper Block
COMPLETE ASSEMBLY	Logan Part No.	409-000	409-002	409-003	409-004	409-005	409-006	409-007
	Bowen No.	25940	2174	8505	9176	8570	9465	8844
TOP THRUST	Logan Part No.
TO CUT COUPLING	Bowen No.
TOP THRUST	Logan Part No.	Q34005
	Bowen No.	8581
SLIP	Logan Part No.	Q35005
	Bowen No.	8587
WIPER BLOCK	Logan Part No.	Q36005
	Bowen No.	8605
BOTTOM NUT	Logan Part No.	Q37005
	Bowen No.	8634
KNIFE BLOCK	Logan Part No.	Q38005
	Bowen No.	22278

Logan Oil Tools reserves the right to change or discontinue designs without notice.

Notes:

- (1) Slip number Q15009 is for 5" 15-21# Csg, for 5" 11.5-13# Csg use Slip number Q40009.
- (2) Where both Wiper Block and Drag Spring parts are shown, the cutter can be ordered with either.
If not specified, Wiper Block parts will be furnished. (Note: Assemblies are priced differently.)

When ordering, please specify:

- (1) Name and number of assembly or part
- (2) Size of pipe to cut
- (3) Whether or not Bottom Nut is to be fitted for collar finder
- (4) Knives with carbide tips available upon request

Recommended Spare Parts:

- | | |
|-----------------------------------|-----------------------------------|
| (1) 6 sets of Knives | (8) 1 set of Wiper Block Screws |
| (2) 2 sets of Knife Pins | (9) 1 set of Grip Jaws |
| (3) 6 sets of Knife Springs | (10) 1 set of Grip Jaw Springs |
| (4) 2 sets of Knife Spring Screws | (11) 1 Wickered Sleeve |
| (5) 1 set of Slips | (12) 1 set of Drag Springs |
| (6) 1 set of Wiper Blocks | (13) 1 set of Drag Springs Screws |
| (7) 1 set of Wiper Block Springs | |

INTERNAL CUTTERS

PIPE SIZE TO CUT		5 IUDP	5 Csg	6 Csg	7 Csg	8-5/8 to 9 Csg	9-5/8 Csg	11-3/4 Csg
CAN BE DRESSED FOR		...	5-1/2 Csg	6-5/8 Csg	7-5/8, 8 Csg	9-5/8 Csg	10-3/4 Csg	12 LP
MINIMUM CUTTER O.D.		3-3/8	4	5	5-11/16	7-1/4	8-1/4	...
STANDARD ASSEMBLY		Drag Spring	Wiper Block	Wiper Block	Wiper Block	Wiper Block	Wiper Block	Wiper Block
COMPLETE ASSEMBLY	Logan Part No.	409-008	409-009	409-010	409-011	409-012	409-013	409-014
	Bowen No.	9081	8200	14785	8745	15532	15080	41876
MANDREL	Logan Part No.	Q1008	Q1009	Q1010	Q1011	Q1012	Q1013	Q1014
	Bowen No.	9082	8176	14786	8746	15533	15081	41877
KNIFE BEARING	Logan Part No.	Q2004	Q2009	Q2009	Q2009	Q2012	Q2012	Q2012
	Bowen No.	8575	8179	8179	8179	15110	15110	15110
	No. Req'd	3	3	3	3	5	5	5
KNIFE SPRING SCREW	Logan Part No.	Q3002	Q3002	Q3002	Q3002	Q3012	Q3012	Q3012
	Bowen No.	8181	8181	8181	8181	9558	9558	9558
	No. Req'd	3	3	3	3	5	5	5
KNIFE SPRING	Logan Part No.	Q4004	Q4009	Q4009	Q4009	Q4012	Q4012	Q4012
	Bowen No.	8629	8180	8180	8180	15111	15111	15111
	No. Req'd	3	3	3	3	5	5	5
KNIFE	Logan Part No.	Q5008	Q5009	Q5009	Q5009	Q5012	Q5012	Q5012
	Bowen No.	9042	8177	8177	8177	15102	15102	15102
	No. Req'd	3	3	3	3	5	5	5
KNIFE BEARING SCREW	Logan Part No.	Q6005	Q6009	Q6009	Q6009	Q6012	Q6013	Q6013
	Bowen No.	8576	8229	8229	8229	15553	15112	15112
	No. Req'd	3	3	3	3	5	5	5
KNIFE PIN	Logan Part No.	Q7004	Q7009	Q7009	Q7009	Q7012	Q7013	Q7013
	Bowen No.	8573	8178	8178	8178	15558	15113	15113
	No. Req'd	3	3	3	3	5	5	5
KNIFE PIN SCREW	Logan Part No.	Q8004	Q8009	Q8009	Q8009	Q8012	Q8012	Q8012
	Bowen No.	8574	8208	8208	8208	15114	15114	15114
	No. Req'd	3	3	3	3	5	5	5
KNIFE BLOCK	Logan Part No.	Q9007	Q9009	Q9009	Q9009	Q9012	Q9012	Q9012
	Bowen No.	8846	8183	8183	8183	15115	15115	15115
	No. Req'd	3	3	3	3	5	5	5
TOP THRUST	Logan Part No.	Q10008	Q10009	Q10010	Q10011	Q10012	Q10013	Q10014
	Bowen No.	8847	8241	14787	8748	15534	15099	41878

Logan Oil Tools reserves the right to change or discontinue designs without notice.

Notes:

- (1) Slip number Q15009 is for 5" 15-21# Csg, for 5" 11.5-13# Csg use Slip number Q40009.
- (2) Where both Wiper Block and Drag Spring parts are shown, the cutter can be ordered with either.
If not specified, Wiper Block parts will be furnished. (Note: Assemblies are priced differently.)

When ordering, please specify:

- (1) Name and number of assembly or part
- (2) Size of pipe to cut
- (3) Whether or not Bottom Nut is to be fitted for collar finder
- (4) Knives with carbide tips available upon request

Recommended Spare Parts:

- | | |
|-----------------------------------|-----------------------------------|
| (1) 6 sets of Knives | (8) 1 set of Wiper Block Screws |
| (2) 2 sets of Knife Pins | (9) 1 set of Grip Jaws |
| (3) 6 sets of Knife Springs | (10) 1 set of Grip Jaw Springs |
| (4) 2 sets of Knife Spring Screws | (11) 1 Wickered Sleeve |
| (5) 1 set of Slips | (12) 1 set of Drag Springs |
| (6) 1 set of Wiper Blocks | (13) 1 set of Drag Springs Screws |
| (7) 1 set of Wiper Block Springs | |

INTERNAL CUTTERS

PIPE SIZE TO CUT		5 IUDP	5 Csg	6 Csg	7 Csg	8-5/8 to 9 Csg	9-5/8 Csg	11-3/4 Csg
CAN BE DRESSED FOR		...	5-1/2 Csg	6-5/8 Csg 7 Csg	7-5/8, 8 Csg 8-1/2 Csg	9-5/8 Csg	10-3/4 Csg 11-3/4 Csg	12 LP
MINIMUM CUTTER O.D.		3-3/8	4	5	5-11/16	7-1/4	8-1/4	...
STANDARD ASSEMBLY		Drag Spring	Wiper Block	Wiper Block	Wiper Block	Wiper Block	Wiper Block	Wiper Block
COMPLETE ASSEMBLY	Logan Part No.	409-008	409-009	409-010	409-011	409-012	409-013	409-014
	Bowen No.	9081	8200	14785	8745	15532	15080	41876
SPLIT THRUST	Logan Part No.	Q11007	Q11009	Q11010	Q11011	Q11012	Q11013	Q11014
	Bowen No.	8848	8185	14788	8750	15535	15084	41879
CONE	Logan Part No.	Q12008	Q12009	Q12010	Q12011	Q12012	Q12013	Q12014
	Bowen No.	9083	8186	14789	8751	15536	15085	41880
MAIN SPRING	Logan Part No.	Q13008	Q13009	Q13010	Q13011	Q13012	Q13013	Q13014
	Bowen No.	9084	8187	14790	8752	15537	15086	41881
SPRING STOP	Logan Part No.	Q14007	Q14009	Q14010	Q14011	Q14012	Q14013	Q14014
	Bowen No.	8851	8209	14791	8753	15538	15087	41882
SLIP	Logan Part No.	Q15008	Q15009	Q15010	Q15011	Q15012	Q15013	Q15014
	Bowen No.	9043	1924	14792	8754	15539	15275	41883
	No. Req'd	3	3	3	3	3	3	3
GRIP JAW SET	Logan Part No.	...	Q16009	Q16010	Q16011	Q16012	Q16013	Q16014
	Bowen No.	...	8193	14793	8755	15540	15089	41884
GRIP JAW SPRING	Logan Part No.	...	Q17009	Q17010	Q17011	Q17012	Q17013	Q17014
	Bowen No.	...	8194	14797	8756	15108	15108	15108
	No. Req'd	...	3	3	3	3	3	3
BOWL	Logan Part No.	Q18008	Q18009	Q18010	Q18011	Q18012	Q18013	Q18014
	Bowen No.	9044	8190	14794	8761	15542	15090	41885
GRIP JAW STOP	Logan Part No.	Q19005	Q19009	Q19010	Q19011	Q19012	Q19013	Q19014
	Bowen No.	8590	8202	14795	8757	15543	15091	41886
GRIP JAW STOP SCREW	Logan Part No.	Q20005	Q20009	Q20010	Q20010	Q20010	Q20010	Q20010
	Bowen No.	62681	25221	8251	8251	8251	8251	8251
	No. Req'd	3	3	3	3	3	3	3
WICKERED SLEEVE LONG	Logan Part No.	Q21008	Q21009	Q21010	Q21011	Q21012	Q21013	Q21014
	Bowen No.	9045	8236	14799	8762	15546	15096	41888
BOTTOM NUT	Logan Part No.	Q22007	Q22009	Q22010	Q22011	Q22012	Q22013	Q22014
	Bowen No.	8857	8196	14800	8763	15547	15097	41889

Logan Oil Tools reserves the right to change or discontinue designs without notice.

Notes:

- (1) Slip number Q15009 is for 5" 15-21# Csg, for 5" 11.5-13# Csg use Slip number Q40009.
- (2) Where both Wiper Block and Drag Spring parts are shown, the cutter can be ordered with either.
If not specified, Wiper Block parts will be furnished. (Note: Assemblies are priced differently.)

When ordering, please specify:

- (1) Name and number of assembly or part
- (2) Size of pipe to cut
- (3) Whether or not Bottom Nut is to be fitted for collar finder
- (4) Knives with carbide tips available upon request

Recommended Spare Parts:

- | | |
|-----------------------------------|-----------------------------------|
| (1) 6 sets of Knives | (8) 1 set of Wiper Block Screws |
| (2) 2 sets of Knife Pins | (9) 1 set of Grip Jaws |
| (3) 6 sets of Knife Springs | (10) 1 set of Grip Jaw Springs |
| (4) 2 sets of Knife Spring Screws | (11) 1 Wickered Sleeve |
| (5) 1 set of Slips | (12) 1 set of Drag Springs |
| (6) 1 set of Wiper Blocks | (13) 1 set of Drag Springs Screws |
| (7) 1 set of Wiper Block Springs | |

INTERNAL CUTTERS

PIPE SIZE TO CUT CAN BE DRESSED FOR	5 IUDP	5 Csg	6 Csg	7 Csg	8-5/8 to 9 Csg	9-5/8 Csg	11-3/4 Csg	
	...	5-1/2 Csg	6-5/8 Csg 7 Csg	7-5/8, 8 Csg, & 8-1/2 Csg	9-5/8 Csg	10-3/4 Csg 11-3/4 Csg	12 LP	
MINIMUM CUTTER O.D.	3-3/8	4	5	5-11/16	7-1/4	8-1/4	...	
STANDARD ASSEMBLY	Drag Spring	Wiper Block	Wiper Block	Wiper Block	Wiper Block	Wiper Block	Wiper Block	
COMPLETE ASSEMBLY	Logan Part No.	409-008	409-009	409-010	409-011	409-012	409-013	409-014
	Bowen No.	9081	8200	14785	8745	15532	15080	41876
WIPER BLOCK	Logan Part No.	...	Q23009	Q23010	Q23011	Q23012	Q23013	Q23014
	Bowen No.	...	8191	14801	8758	15548	15098	41887
	No. Req'd	...	3	3	3	3	3	3
WIPER BLOCK SPRING	Logan Part No.	...	Q24005	Q24010	Q24010	Q24012	Q24012	Q24012
	Bowen No.	...	8599	8759	8759	15276	15276	15276
	No. Req'd	...	24	24	24	36	36	36
WIPER BLOCK SCREW	Logan Part No.	...	Q25005	Q25010	Q25010	Q25010	Q25010	Q25010
	Bowen No.	...	8856	8760	8760	8760	8760	8760
	No. Req'd	...	6	6	6	6	6	6
BOWL DRAG SPRING TYPE	Logan Part No.	...	Q26005
	Bowen No.	...	8201
MANDREL EXTENSION	Logan Part No.	Q27008	Q27009	Q27010	Q27011	Q27012	Q27013	Q27014
	Bowen No.	9093	8237	14796	8246	15544	15092	41892
DRAG SPRING	Logan Part No.	Q28008	Q28009	Q28010	Q28010	Q28012	Q28012	Q28014
	Bowen No.	9092	8203	8247	8247	15093	15093	41890
	No. Req'd	3	3	3	3	3	3	3
DRAG SPRING RING	Logan Part No.	Q29007	Q29009	Q29010	Q29011	Q29012	Q29013	Q29014
	Bowen No.	8855	8205	14798	8248	15545	15095	41891
DRAG SPRING SCREW	Logan Part No.	Q20005	Q20009	Q20010	Q20010	Q20010	Q20010	Q20010
	Bowen No.	62681	25221	8251	8251	8251	8251	8251
	No. Req'd	6	3	3	3	3	3	3
WICKERED SLEEVE SHORT	Logan Part No.
	Bowen No.
DRAG SPRING SHORT	Logan Part No.
	Bowen No.
	No. Req'd
ROD KNIFE	Logan Part No.
	Bowen No.

Logan Oil Tools reserves the right to change or discontinue designs without notice.

Notes:

- (1) Slip number Q15009 is for 5" 15-21# Csg, for 5" 11.5-13# Csg use Slip number Q40009.
- (2) Where both Wiper Block and Drag Spring parts are shown, the cutter can be ordered with either.
If not specified, Wiper Block parts will be furnished. (Note: Assemblies are priced differently.)

When ordering, please specify:

- (1) Name and number of assembly or part
- (2) Size of pipe to cut
- (3) Whether or not Bottom Nut is to be fitted for collar finder
- (4) Knives with carbide tips available upon request

Recommended Spare Parts:

- | | |
|-----------------------------------|-----------------------------------|
| (1) 6 sets of Knives | (8) 1 set of Wiper Block Screws |
| (2) 2 sets of Knife Pins | (9) 1 set of Grip Jaws |
| (3) 6 sets of Knife Springs | (10) 1 set of Grip Jaw Springs |
| (4) 2 sets of Knife Spring Screws | (11) 1 Wickered Sleeve |
| (5) 1 set of Slips | (12) 1 set of Drag Springs |
| (6) 1 set of Wiper Blocks | (13) 1 set of Drag Springs Screws |
| (7) 1 set of Wiper Block Springs | |

INTERNAL CUTTERS

PIPE SIZE TO CUT		5 IUDP	5 Csg	6 Csg	7 Csg	8-5/8 to 9 Csg	9-5/8 Csg	11-3/4 Csg
CAN BE DRESSED FOR		...	5-1/2 Csg	6-5/8 Csg 7 Csg	7-5/8, 8 Csg, & 8-1/2 Csg	9-5/8 Csg	10-3/4 Csg 11-3/4 Csg	12 LP
MINIMUM CUTTER O.D.		3-3/8	4	5	5-11/16	7-1/4	8-1/4	...
STANDARD ASSEMBLY		Drag Spring	Wiper Block	Wiper Block	Wiper Block	Wiper Block	Wiper Block	Wiper Block
COMPLETE ASSEMBLY	Logan Part No.	409-008	409-009	409-010	409-011	409-012	409-013	409-014
	Bowen No.	9081	8200	14785	8745	15532	15080	41876
TOP THRUST	Logan Part No.	...	Q34009	Q34010	Q34011	Q34012	Q39015	Q34014
TO CUT COUPLING	Bowen No.	...	8184	14802	8749	15541	15083	41896
TOP THRUST	Logan Part No.
	Bowen No.
SLIP	Logan Part No.
	Bowen No.
WIPER BLOCK	Logan Part No.
	Bowen No.
BOTTOM NUT	Logan Part No.
	Bowen No.
KNIFE BLOCK	Logan Part No.
	Bowen No.

Logan Oil Tools reserves the right to change or discontinue designs without notice.

Notes:

(1) Slip number Q15009 is for 5" 15-21# Csg, for 5" 11.5-13# Csg use Slip number Q40009.

(2) Where both Wiper Block and Drag Spring parts are shown, the cutter can be ordered with either.

If not specified, Wiper Block parts will be furnished. (Note: Assemblies are priced differently.)

When ordering, please specify:

- (1) Name and number of assembly or part
- (2) Size of pipe to cut
- (3) Whether or not Bottom Nut is to be fitted for collar finder
- (4) Knives with carbide tips available upon request

Recommended Spare Parts:

- | | |
|-----------------------------------|-----------------------------------|
| (1) 6 sets of Knives | (8) 1 set of Wiper Block Screws |
| (2) 2 sets of Knife Pins | (9) 1 set of Grip Jaws |
| (3) 6 sets of Knife Springs | (10) 1 set of Grip Jaw Springs |
| (4) 2 sets of Knife Spring Screws | (11) 1 Wickered Sleeve |
| (5) 1 set of Slips | (12) 1 set of Drag Springs |
| (6) 1 set of Wiper Blocks | (13) 1 set of Drag Springs Screws |
| (7) 1 set of Wiper Block Springs | |

INTERNAL CUTTERS

PIPE SIZE TO CUT		13 & & 13-3/8 Csg	16 Csg	20 Tbg				
CAN BE DRESSED FOR		...	18-5/8 Csg	20-3/4 Csg				
MINIMUM CUTTER O.D.		11-3/4	14-1/2	18-5/8				
STANDARD ASSEMBLY		Wiper Block	Wiper Block	Wiper Block				
COMPLETE ASSEMBLY	Logan Part No.	409-015	409-016	409-017				
	Bowen No.	19525	21240	19760				
MANDREL	Logan Part No.	Q1015	Q1016	Q1017				
	Bowen No.	19526	21241	19761				
KNIFE BEARING	Logan Part No.	Q2012	Q2012	Q2012				
	Bowen No.	15110	15110	15110				
	No. Req'd	5	5	5				
KNIFE SPRING SCREW	Logan Part No.	Q3012	Q3012	Q3012				
	Bowen No.	9558	9558	9558				
	No. Req'd	5	5	5				
KNIFE SPRING	Logan Part No.	Q4012	Q4012	Q4012				
	Bowen No.	15111	15111	15111				
	No. Req'd	5	5	5				
KNIFE	Logan Part No.	Q5012	Q5012	Q5012				
	Bowen No.	15102	15102	15102				
	No. Req'd	5	5	5				
KNIFE BEARING SCREW	Logan Part No.	Q6013	Q6013	Q6013				
	Bowen No.	23003	15112	15112				
	No. Req'd	5	5	5				
KNIFE PIN	Logan Part No.	Q7015	Q7013	Q7013				
	Bowen No.	39231	15113	15113				
	No. Req'd	5	5	5				
KNIFE PIN SCREW	Logan Part No.	Q8012	Q8012	Q8012				
	Bowen No.	15114	15114	15114				
	No. Req'd	5	5	5				
KNIFE BLOCK	Logan Part No.	Q9012	Q9012	Q9012				
	Bowen No.	15115	15115	15115				
	No. Req'd	5	5	5				

Logan Oil Tools reserves the right to change or discontinue designs without notice.

Notes:

- (1) Slip number Q15009 is for 5" 15-21# Csg, for 5" 11.5-13# Csg use Slip number Q40009.
- (2) Where both Wiper Block and Drag Spring parts are shown, the cutter can be ordered with either.
If not specified, Wiper Block parts will be furnished. (Note: Assemblies are priced differently.)

When ordering, please specify:

- (1) Name and number of assembly or part
- (2) Size of pipe to cut
- (3) Whether or not Bottom Nut is to be fitted for collar finder
- (4) Knives with carbide tips available upon request

Recommended Spare Parts:

- | | |
|-----------------------------------|-----------------------------------|
| (1) 6 sets of Knives | (8) 1 set of Wiper Block Screws |
| (2) 2 sets of Knife Pins | (9) 1 set of Grip Jaws |
| (3) 6 sets of Knife Springs | (10) 1 set of Grip Jaw Springs |
| (4) 2 sets of Knife Spring Screws | (11) 1 Wickered Sleeve |
| (5) 1 set of Slips | (12) 1 set of Drag Springs |
| (6) 1 set of Wiper Blocks | (13) 1 set of Drag Springs Screws |
| (7) 1 set of Wiper Block Springs | |

INTERNAL CUTTERS

PIPE SIZE TO CUT		13 & 13-3/8 Csg	16 Csg	20 Csg				
CAN BE DRESSED FOR		...	18-5/8 Csg	20-3/4 Csg				
MINIMUM CUTTER O.D.		11-3/4	14-1/2	18-5/8				
STANDARD ASSEMBLY		Wiper Block	Wiper Block	Wiper Block				
COMPLETE ASSEMBLY	Logan Part No.	409-015	409-016	409-017				
	Bowen No.	19525	21240	19760				
TOP THRUST	Logan Part No.	Q10015	Q10016	Q10017				
	Bowen No.	19527	21242	19762				
SPLIT THRUST	Logan Part No.	Q11015	Q11016	Q11017				
	Bowen No.	19528	21243	19763				
CONE	Logan Part No.	Q12015	Q12016	Q12017				
	Bowen No.	19529	21244	19764				
MAIN SPRING	Logan Part No.	Q13015	Q13016	Q13017				
	Bowen No.	19530	21245	19765				
SPRING STOP	Logan Part No.	Q14015	Q14016	Q14017				
	Bowen No.	19531	21246	19766				
SLIP	Logan Part No.	Q15015	Q15016	Q15017				
	Bowen No.	19532	21247	19767				
	No. Req'd	3	3	3				
GRIP JAW SET	Logan Part No.	Q16015	Q16016	Q16017				
	Bowen No.	19533	21248	19768				
GRIP JAW SPRING	Logan Part No.	Q17015	Q17016	8234				
	Bowen No.	19534	21249	19769				
	No. Req'd	4	4	4				
BOWL	Logan Part No.	Q18015	Q18016	Q18017				
	Bowen No.	19535	21250	19770				
GRIP JAW STOP	Logan Part No.	Q19015	Q19016	Q19017				
	Bowen No.	19536	21251	19771				
GRIP JAW STOP SCREW	Logan Part No.	Q20015	Q20016	Q20010				
	Bowen No.	41871	21679	8251				
	No. Req'd	3	3	3				

Logan Oil Tools reserves the right to change or discontinue designs without notice.

Notes:

- (1) Slip number Q15009 is for 5" 15-21# Csg, for 5" 11.5-13# Csg use Slip number Q40009.
- (2) Where both Wiper Block and Drag Spring parts are shown, the cutter can be ordered with either.
If not specified, Wiper Block parts will be furnished. (Note: Assemblies are priced differently.)

When ordering, please specify:

- (1) Name and number of assembly or part
- (2) Size of pipe to cut
- (3) Whether or not Bottom Nut is to be fitted for collar finder
- (4) Knives with carbide tips available upon request

Recommended Spare Parts:

- | | |
|-----------------------------------|-----------------------------------|
| (1) 6 sets of Knives | (8) 1 set of Wiper Block Screws |
| (2) 2 sets of Knife Pins | (9) 1 set of Grip Jaws |
| (3) 6 sets of Knife Springs | (10) 1 set of Grip Jaw Springs |
| (4) 2 sets of Knife Spring Screws | (11) 1 Wickered Sleeve |
| (5) 1 set of Slips | (12) 1 set of Drag Springs |
| (6) 1 set of Wiper Blocks | (13) 1 set of Drag Springs Screws |
| (7) 1 set of Wiper Block Springs | |

INTERNAL CUTTERS

PIPE SIZE TO CUT		13 & 13-3/8 Csg	16 Csg	20 Csg				
CAN BE DRESSED FOR CUTTER O.D. (MINIMUM)		...	18-5/8 Csg	20-3/4 Csg				
STANDARD ASSEMBLY		Wiper Block	Wiper Block	Wiper Block				
COMPLETE ASSEMBLY	Logan Part No.	409-015	409-016	409-017				
	Bowen No.	19525	21240	19760				
WICKERED SLEEVE LONG	Logan Part No.	Q21015	Q21016	Q21017				
	Bowen No.	19540	21253	19778				
BOTTOM NUT	Logan Part No.	Q22015	Q22016	Q22017				
	Bowen No.	19541	21254	19779				
WIPER BLOCK	Logan Part No.	Q23015	Q23016	Q23017				
	Bowen No.	19542	21252	19772				
	No. Req'd	6	8	6				
WIPER BLOCK SPRING	Logan Part No.	Q24012	Q24012	Q24012				
	Bowen No.	15276	15276	15276				
	No. Req'd	72	54	48				
WIPER BLOCK SCREW	Logan Part No.	Q25010	Q25016	Q25010				
	Bowen No.	8760	21678	8760				
	No. Req'd	6	12	6				
BOWL DRAG SPRING TYPE	Logan Part No.				
	Bowen No.				
MANDREL EXTENSION	Logan Part No.	Q27015	Q27016	Q27017				
	Bowen No.	19537	21255	19773				
DRAG SPRING	Logan Part No.	Q28015	Q28016	Q28017				
	Bowen No.	19538	21256	19774				
	No. Req'd	6	6	6				
DRAG SPRING RING	Logan Part No.	Q29015	Q29016	Q29017				
	Bowen No.	19539	21257	19799				
DRAG SPRING SCREW	Logan Part No.	Q20010	Q20010	Q20010				
	Bowen No.	8251	8251	8251				
	No. Req'd	6	6	6				

Logan Oil Tools reserves the right to change or discontinue designs without notice.

Notes:

- (1) Slip number Q15009 is for 5" 15-21# Csg, for 5" 11.5-13# Csg use Slip number Q40009.
- (2) Where both Wiper Block and Drag Spring parts are shown, the cutter can be ordered with either.
If not specified, Wiper Block parts will be furnished. (Note: Assemblies are priced differently.)

When ordering, please specify:

- (1) Name and number of assembly or part
- (2) Size of pipe to cut
- (3) Whether or not Bottom Nut is to be fitted for collar finder
- (4) Knives with carbide tips available upon request

Recommended Spare Parts:

- | | |
|-----------------------------------|-----------------------------------|
| (1) 6 sets of Knives | (8) 1 set of Wiper Block Screws |
| (2) 2 sets of Knife Pins | (9) 1 set of Grip Jaws |
| (3) 6 sets of Knife Springs | (10) 1 set of Grip Jaw Springs |
| (4) 2 sets of Knife Spring Screws | (11) 1 Wickered Sleeve |
| (5) 1 set of Slips | (12) 1 set of Drag Springs |
| (6) 1 set of Wiper Blocks | (13) 1 set of Drag Springs Screws |
| (7) 1 set of Wiper Block Springs | |

INTERNAL CUTTERS

PIPE SIZE TO CUT		13 & 13-3/8 Csg	16 Csg	20 Csg				
CAN BE DRESSED FOR		...	18-5/8 Csg	20-3/4 Csg				
MINIMUM CUTTER O.D.		11-3/4	14-1/2	18-5/8				
STANDARD ASSEMBLY		Wiper Block	Wiper Block	Wiper Block				
COMPLETE ASSEMBLY	Logan Part No.	409-015	409-016	409-017				
	Bowen No.	19525	21240	19760				
WICKERED SLEEVE SHORT	Logan Part No.				
	Bowen No.				
DRAG SPRING SHORT (3 req'd)	Logan Part No.				
	Bowen No.				
	No. Req'd				
ROD KNIFE	Logan Part No.				
	Bowen No.				
TOP THRUST TO CUT COUPLING	Logan Part No.				
	Bowen No.				
TOP THRUST	Logan Part No.				
	Bowen No.				
SLIP	Logan Part No.				
	Bowen No.				
WIPER BLOCK	Logan Part No.				
	Bowen No.				
BOTTOM NUT	Logan Part No.				
	Bowen No.				
KNIFE BLOCK	Logan Part No.				
	Bowen No.				

Logan Oil Tools reserves the right to change or discontinue designs without notice.

Notes:

- (1) Slip number Q15009 is for 5" 15-21# Csg, for 5" 11.5-13# Csg use Slip number Q40009.
- (2) Where both Wiper Block and Drag Spring parts are shown, the cutter can be ordered with either.
If not specified, Wiper Block parts will be furnished. (Note: Assemblies are priced differently.)

When ordering, please specify:

- (1) Name and number of assembly or part
- (2) Size of pipe to cut
- (3) Whether or not Bottom Nut is to be fitted for collar finder
- (4) Knives with carbide tips available upon request

Recommended Spare Parts:

- | | |
|-----------------------------------|-----------------------------------|
| (1) 6 sets of Knives | (8) 1 set of Wiper Block Screws |
| (2) 2 sets of Knife Pins | (9) 1 set of Grip Jaws |
| (3) 6 sets of Knife Springs | (10) 1 set of Grip Jaw Springs |
| (4) 2 sets of Knife Spring Screws | (11) 1 Wickered Sleeve |
| (5) 1 set of Slips | (12) 1 set of Drag Springs |
| (6) 1 set of Wiper Blocks | (13) 1 set of Drag Springs Screws |
| (7) 1 set of Wiper Block Springs | |

INTERNAL CUTTERS

PIPE SIZE TO CUT		2-3/8 Tbg	3-1/2 OD Tbg	3-1/2 OD Tbg	4-1/2 FH DP	4-1/2 FH DP	4-1/2 IF DP	4-1/2 IF DP
CAN BE DRESSED TO CUT		2-7/8 IF DP & 2-7/8 Tbg	4 OD Tbg	4-1/2 OD Tbg	4-1/2 X-Hole DP	4-1/2 OD Csg	4-1/2 OD Tbg & Csg	4-3/4 OD Csg
CUTTER O.D. (MINIMUM)		1-13/16	2-5/8	2-5/8	2-1/2	2-1/2	3-3/8	3-3/8
STANDARD ASSEMBLY		Drag Spring	Wiper Block	Wiper Block	Drag Spring	Drag Spring	Wiper Block	Wiper Block
COMPLETE ASSEMBLY	Logan Part No.	409-002	409-005	409-005	409-006	409-006	409-007	409-007
	Bowen No.	2174	8570	8570	9465	9465	8844	8844
TOP THRUST	Logan Part No.	Q39000	Q39003	Q34005	Q10008
	Bowen No.	8437	8613	8581	8847
SLIP	Logan Part No.	Q40000	Q40003	Q35005	...	Q40006	Q40007	Q40007
	Bowen No.	2181	8577	8587	...	23945	8932	8932
	No. Req'd	3	3	3	...	3	3	3
WIPER BLOCK	Logan Part No.	...	Q41003	Q36005	Q41007	Q41007
	Bowen No.	...	8614	8605	8933	8933
	No. Req'd	...	3	3	3	3
DRAG SPRING	Logan Part No.	...	Q42003	...	Q42005	Q42006	...	Q42005
	Bowen No.	...	8611	...	8611	23946	...	8611
	No. Req'd	...	3	...	3	3	...	3
BOTTOM NUT	Logan Part No.	...	Q43003	Q43004	Q43005	Q43008
	Bowen No.	...	8602	8634	9457	8934
KNIFE BLOCK	Logan Part No.	Q38005
	Bowen No.	22278
	No. Req'd	3
TOP THRUST CUT COUPLING	Logan Part No.
	Bowen No.
KNIFE	Logan Part No.
	Bowen No.

Logan Oil Tools reserves the right to change or discontinue designs without notice.

Notes:

- (1) Slip number Q15009 is for 5" 15-21# Csg, for 5" 11.5-13# Csg use Slip number Q40009.
- (2) Where both Wiper Block and Drag Spring parts are shown, the cutter can be ordered with either.
If not specified, Wiper Block parts will be furnished. (Note: Assemblies are priced differently.)

When ordering, please specify:

- (1) Name and number of assembly or part
- (2) Size of pipe to cut
- (3) Whether or not Bottom Nut is to be fitted for collar finder
- (4) Knives with carbide tips available upon request

Recommended Spare Parts:

- | | |
|-----------------------------------|-----------------------------------|
| (1) 6 sets of Knives | (8) 1 set of Wiper Block Screws |
| (2) 2 sets of Knife Pins | (9) 1 set of Grip Jaws |
| (3) 6 sets of Knife Springs | (10) 1 set of Grip Jaw Springs |
| (4) 2 sets of Knife Spring Screws | (11) 1 Wickered Sleeve |
| (5) 1 set of Slips | (12) 1 set of Drag Springs |
| (6) 1 set of Wiper Blocks | (13) 1 set of Drag Springs Screws |
| (7) 1 set of Wiper Block Springs | |

INTERNAL CUTTERS

PIPE SIZE TO CUT		4-1/2 IFDP	4-1/2 IFDP	5 OD Csg	5-1/2 Csg	6 OD Csg	6 OD Csg	7 OD Csg
CAN BE DRESSED TO CUT		5 OD Csg	5-1/2 OD Csg	5-1/2 OD Csg	5-3/4 OD Csg	6-5/8 OD Csg	7 OD Csg	7-5/8 OD Csg
CUTTER O.D. (MINIMUM)		3-3/8	3-3/8	4	4	5	5	5-11/16
STANDARD ASSEMBLY		Wiper Block	Wiper Block	Wiper Block	Wiper Block	Wiper Block	Wiper Block	Wiper Block
COMPLETE ASSEMBLY	Logan Part No.	409-007	409-007	409-009	409-009	409-010	409-010	409-011
	Bowen No.	8844	8844	8200	8200	14785	14785	8745
TOP THRUST	Logan Part No.	Q10008	Q10008	Q39009	Q39020	Q34010	...	Q34011
	Bowen No.	8847	8847	8242	54550	14802	...	8749
SLIP	Logan Part No.	Q40008	Q40020	Q40009	Q40021	Q40010	Q40011	Q40012
	Bowen No.	14004	53055	8405	54551	14803	29499	8764
	No. Req'd	3	3	3	3	3	3	3
WIPER BLOCK	Logan Part No.	Q41008	Q41020	Q41009	Q41021	Q41010	Q41011	Q41012
	Bowen No.	14001	53056	8219	54552	14818	20982	8770
	No. Req'd	3	3	3	3	3	3	3
DRAG SPRING	Logan Part No.	Q42005	...	Q42009	Q42013	Q42010	...	Q42010
	Bowen No.	8611	...	8207	54553	8249	...	8249
	No. Req'd	3	...	3	3	3	...	3
BOTTOM NUT	Logan Part No.	Q43009	Q43009	Q43010	Q43010	Q43011	Q43012	Q43013
	Bowen No.	14002	14002	8234	8234	14817	36498	8774
KNIFE BLOCK	Logan Part No.	Q44009	Q44010
	Bowen No.	14003	53057
	No. Req'd	3	3
TOP THRUST CUT COUPLING	Logan Part No.	Q45011	Q45011	...
	Bowen No.	14816	14816	...
KNIFE	Logan Part No.	...	Q5008
	Bowen No.	...	9042

Logan Oil Tools reserves the right to change or discontinue designs without notice.

Notes:

- (1) Slip number Q15009 is for 5" 15-21# Csg, for 5" 11.5-13# Csg use Slip number Q40009.
- (2) Where both Wiper Block and Drag Spring parts are shown, the cutter can be ordered with either.
If not specified, Wiper Block parts will be furnished. (Note: Assemblies are priced differently.)

When ordering, please specify:

- (1) Name and number of assembly or part
- (2) Size of pipe to cut
- (3) Whether or not Bottom Nut is to be fitted for collar finder
- (4) Knives with carbide tips available upon request

Recommended Spare Parts:

- | | |
|-----------------------------------|-----------------------------------|
| (1) 6 sets of Knives | (8) 1 set of Wiper Block Screws |
| (2) 2 sets of Knife Pins | (9) 1 set of Grip Jaws |
| (3) 6 sets of Knife Springs | (10) 1 set of Grip Jaw Springs |
| (4) 2 sets of Knife Spring Screws | (11) 1 Wickered Sleeve |
| (5) 1 set of Slips | (12) 1 set of Drag Springs |
| (6) 1 set of Wiper Blocks | (13) 1 set of Drag Springs Screws |
| (7) 1 set of Wiper Block Springs | |