

XEU1 -Heater Pipe Mounting Bracket (PMB) Installation Instructions

Ensure heater model number corresponds with the correct model and size of mounting bracket identified on the outside of packaging.

WARNING!

Refer to heater owner's manual for mounting specifications and conditions. If the heater is installed on a structure that is to be transported, provide additional support for heater during transit. Suspended weight should not exceed 250 lbs (113 kg).

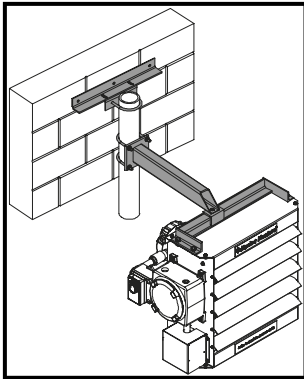

Pipe Mounting Bracket (PMB)

Note: Installer is required to supply:

- A) one piece of 3", schedule 40 or heavier, steel pipe cut to required length.
- B) a method of fastening Wall Angle Bracket to supporting structure. If using bolts, we recommend four 3/8" diameter, grade 5 bolts.
- C) a fastener to attach Pipe Base Plate to floor. This kit provides a 3/8" - UNC x 2-3/4" Anchor Bolt for concrete floors.

STEP 1

Install Wall Angle Bracket to the wall (installer supplied fastening method) at an appropriate height to support the top of the pipe.

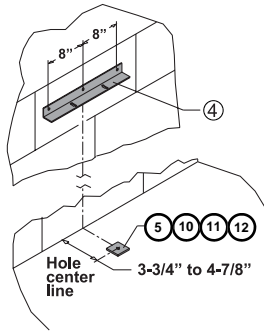

STEP 2

Install Pipe Base Plate to floor (installer supplied fastening method or 3/8" - UNC x 2-3/4" Anchor Bolt, washer and 3/8" nut). To install Anchor Bolt, drill a 3/8" diameter hole a minimum of 2" deep into floor. Screw the nut, with washer, onto bolt 1/8" past the end. Drive bolt through Pipe Base Plate hole into drilled hole so that nut and washer are seated on Pipe Base Plate. Turn nut until tight.

PACKAGE CONTENTS

Item	Qty.	Description
①	1	Cantilever Arm Assembly
②	1	Heater L-Bracket
③	1	Pipe Angle Bracket
④	1	Wall Angle Bracket
⑤	1	Pipe Base Plate
⑥	4	Bolt, 1/2" - 13UNC x 1"
⑦	8	Lock Washer, 3/8"
⑧	3	U-Bolt, 3/8" - 16UNC x 3-1/2"
⑨	2	Bolt, 3/8" - 16UNC x 1"
⑩	1	Anchor Bolt, 3/8"- UNC x 2-3/4"
⑪	9	Nut, 3/8" - 16UNC
⑫	5	Flat Washer, 3/8"
⑬	4	Flange Nut, 1/2" - 13UNC
⑭	1	Bolt, 5/8" - 11UNC x 1-1/4"

STEP 3

Using two U-bolts, lock washers, and 3/8" UNC nuts, fasten short Pipe Angle Bracket and Cantilever Arm Assembly to the desired location on the 3" steel pipe (hand tighten initially to permit parts to be adjusted to final location after pipe is erected).

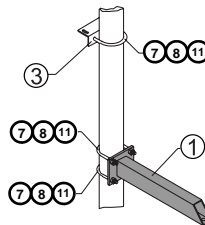

STEP 4

Erect pipe on Base Plate. Using two 3/8" -16UNC x 1" bolts, two flat washers per bolt, lock washers and 3/8" -16UNC nuts, fasten short Pipe Angle Bracket to Wall Angle Bracket. Position Cantilever Arm Assembly at final mounting height and tighten U-bolts.

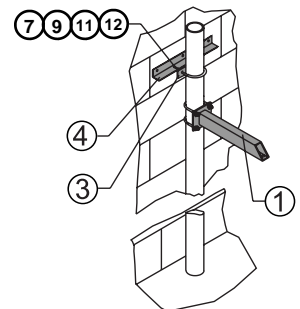

STEP 5

Bolt Heater L-Bracket to heater using four 1/2" - 13UNC x 1" bolts and 1/2" - 13UNC flange nuts.

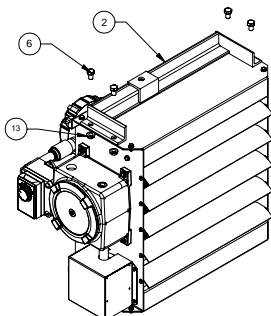

STEP 6

Lift heater and fasten to Cantilever Arm Assembly using one 5/8" - 11UNC x 1-1/4" bolt.

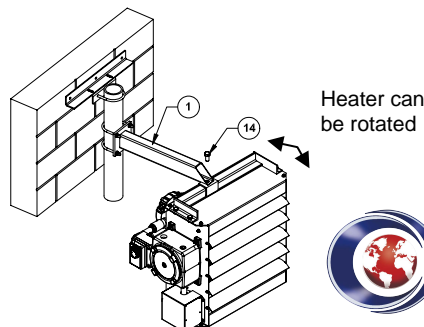

CANAM
- est. 1990
pipe & supply